

OPERATION MANUAL

EARTH/GROUND RESISTANCE METER

MRU-200-GPS

MRU-200-GPS

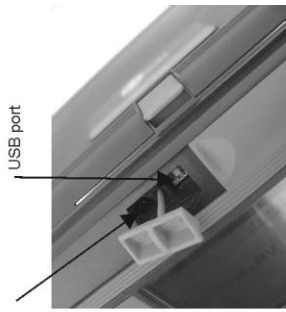

USB port

Charger socket

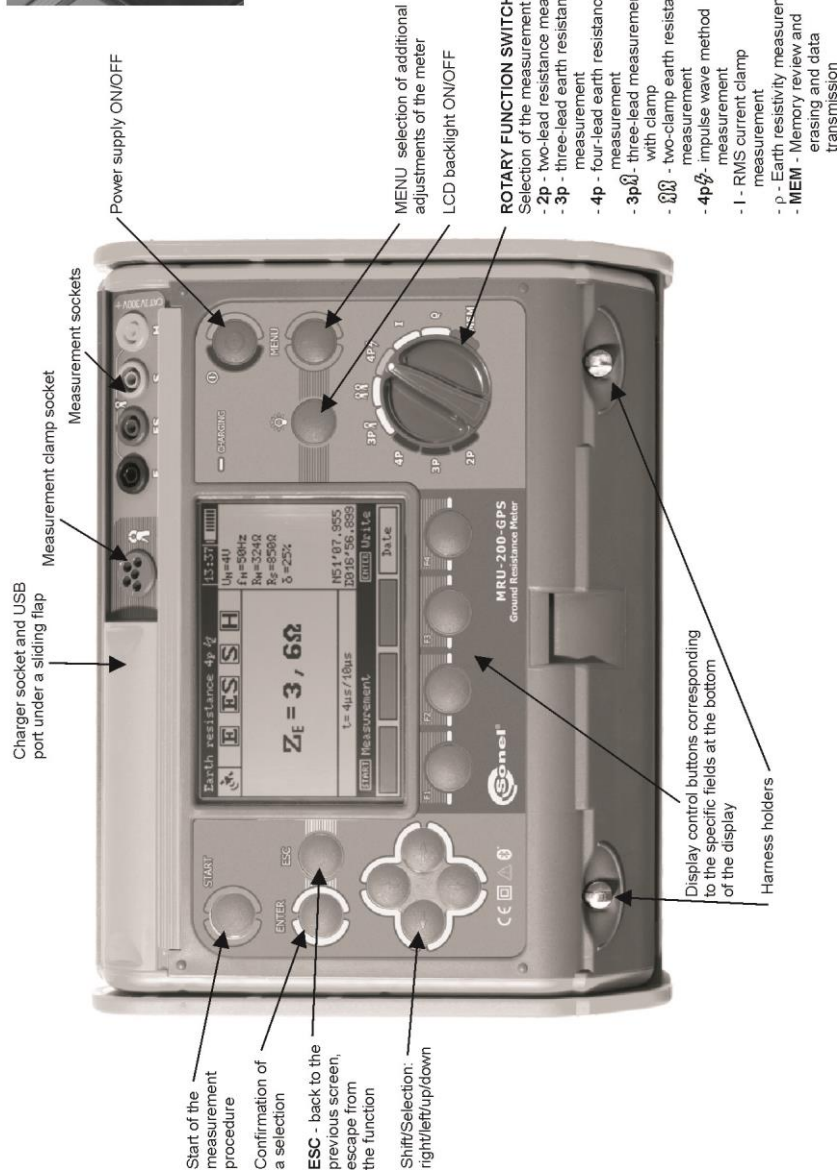

Charger socket and USB port under a sliding flap

Measurement clamp socket

Measurement sockets

Power supply ON/OFF

MENU selection of additional adjustments of the meter
LCD backlight ON/OFF

ROTARY FUNCTION SWITCH
Selection of the measurement function:

- 2p - two-lead resistance measurement
- 3p - three-lead earth resistance measurement
- 4p - four-lead earth resistance measurement
- 3p \oplus - three-lead measurement with clamp
- \oplus - two-lead earth resistance measurement
- 4p \oplus - impulse wave method measurement
- I - RMS current clamp measurement
- p - Earth resistivity measurement
- MEM - Memory review and erasing and data transmission

Start of the measurement procedure

Confirmation of a selection

ESC - back to the previous screen, escape from the function

Shift/Selection: right/left/up/down

Display control buttons corresponding to the specific fields at the bottom of the display

Harness holders



OPERATING MANUAL

EARTH/GROUND RESISTANCE METER MRU-200-GPS



SONEL TEST & MEASUREMENT, Inc.

Santa Clara, Ca. USA

SONEL S. A.

Świdnica, Poland

Version 1.06 Apr 12, 2017

Please acquaint yourself with this manual in order to avoid measuring errors and problems related to operation of the meter.

This device complies with part 15 of the FCC Rules. Operation is subject to the following two conditions: (1) This device may not cause harmful interference, and (2) this device must accept any interference received, including interference that may cause undesired operation.

This equipment has been tested and found to comply with the limits for a Class A digital device, pursuant to part 15 of the FCC Rules. These limits are designed to provide reasonable protection against harmful interference when the equipment is operated in a commercial environment. This equipment generates, uses, and can radiate radio frequency energy and, if not installed and used in accordance with the instruction manual, may cause harmful interference to radio communications. Operation of this equipment in a residential area is likely to cause harmful interference in which case the user will be required to correct the interference at his own expense.

Responsible for conformity:
Sonel Test and Measurement, Inc.
3350 Scott Blvd, Bldg 55, Unit 1
Santa Clara, CA 95054
USA

www.SonelTest.com
office@SonelTest.com

tel. +1 408 898 2215

CAUTION:

Equipment changes or modifications not expressly approved by SONEL TEST & MEASUREMENT Inc., the party responsible for FCC compliance, could void the user's authority to operate the equipment, and could create a hazardous condition.

TABLE OF CONTENTS

1	SAFETY	5
2	MENU.....	6
2.1	WIRELESS TRANSMISSION	6
2.2	GPS SETTINGS.....	6
2.3	MEASUREMENT SETTINGS	7
2.3.1	<i>Mains frequency</i>	7
2.3.2	<i>Calibration of the current clamps</i>	8
2.3.3	<i>Earth resistivity settings</i>	11
2.4	METER SETTINGS.....	12
2.4.1	<i>LCD contrast</i>	12
2.4.2	<i>LCD Backlight</i>	12
2.4.3	<i>AUTO-OFF settings</i>	12
2.4.4	<i>Display settings</i>	12
2.4.5	<i>Date and time</i>	13
2.4.6	<i>Battery discharge procedure</i>	13
2.4.7	<i>Software upgrade</i>	13
2.5	LANGUAGE CHOICE	14
2.6	INFORMATION ON THE MANUFACTURER.....	14
3	MEASUREMENTS.....	14
3.1	MEASUREMENT OF EARTH CONNECTION AND EQUIPOTENTIAL BONDING (2P)	14
3.2	CALIBRATION OF THE TEST LEADS	16
3.2.1	<i>Auto-zeroing on</i>	16
3.2.2	<i>Auto-zeroing off</i>	17
3.3	MEASUREMENT 3P.....	17
3.4	MEASUREMENT 4P	21
3.5	MEASUREMENT 3P + CLAMP	24
3.6	MEASUREMENT 3P + ERP-1 ADAPTER	28
3.7	TWO-CLAMP MEASUREMENT.....	31
3.8	MEASUREMENT 4P ! (IMPULSE METHOD).....	33
3.9	CURRENT MEASUREMENT	37
3.10	EARTH RESISTIVITY MEASUREMENTS	38
4	MEMORY.....	41
4.1	SAVING MEASUREMENT RESULTS IN THE MEMORY	42
4.2	ERASING MEMORY.....	43
4.3	MEMORY BROWSING.....	44
5	DATA TRANSMISSION.....	45
5.1	COMPUTER CONNECTION ACCESSORIES.....	45
5.2	CONNECTION OF THE METER TO A COMPUTER	45
5.3	DATA TRANSMISSION WITH BLUETOOTH MODULE.....	45

- 6 POWER SUPPLY47**
 - 6.1 MONITORING OF THE POWER SUPPLY VOLTAGE47
 - 6.2 REPLACEMENT OF BATTERIES47
 - 6.3 FUSE REPLACEMENT48
 - 6.4 CHARGING OF BATTERIES48
 - 6.5 DISCHARGING OF BATTERIES49
 - 6.6 GENERAL PRINCIPLES REGARDING USING NI-MH BATTERIES.....50
- 7 CLEANING AND MAINTENANCE51**
- 8 STORAGE.....51**
- 9 DISMANTLING AND DISPOSAL51**
- 10 TECHNICAL DATA51**
 - 10.1 BASIC DATA.....51
 - 10.2 ADDITIONAL DATA.....55
 - 10.2.1 *Influence of the serial interference voltage U_z upon earth resistance measurements for functions 3P, 4P, 3P + clamp.....55*
 - 10.2.2 *Influence of the serial interference voltage V_z upon earth resistance measurements for function ρ55*
 - 10.2.3 *Influence of the auxiliary electrodes upon earth resistance measurements for function 3P, 4P, 3P + clamp.....55*
 - 10.2.4 *Influence of the auxiliary electrodes upon earth resistance measurements for function ρ56*
 - 10.2.5 *Influence of the auxiliary electrodes upon earth resistance measurements by means of the percussive method.....56*
 - 10.2.6 *Influence of the interference current I_z upon the result of the earth resistance measurement 3P+clamp56*
 - 10.2.7 *Influence of interference current upon the result of the earth resistance measurement using double clamps57*
 - 10.2.8 *Influence of the relation of the resistance measured with clamp for the multiple earthing branch to the resultant resistance (3P + clamp).....57*
 - 10.2.9 *Additional uncertainties in accordance with IEC 61557-4 (2P)57*
 - 10.2.10 *Additional uncertainties in accordance with IEC 61557-5 (3P, 4P, 3P + clamp).....57*
- 11 ACCESSORIES58**
 - 11.1 BASIC ACCESSORIES58
 - 11.2 ADDITIONAL ACCESSORIES58
- 12 POSITIONS OF THE METER’S COVER60**
- 13 MANUFACTURER.....60**

1 Safety

Electrical systems depend upon effective grounding for safety. The MRU-200-GPS meter has been designed to perform earth ground resistance measurements to determine whether the grounding of electrical systems meets electrical safety code requirements. For correct operation, and to ensure the accuracy of test results, observe the following instructions:

- Before operating the meter, acquaint yourself thoroughly with this manual and adhere to all safety regulations and specifications.
- The MRU-200-GPS meter has been designed to test and measure the resistance of earth/ground connections and equipotential bonding, measure ground resistivity, as well as measure current. Any application that differs from those specified in this manual may result in damage to the device and injury to the user.
- The device must be operated only by appropriately qualified personnel trained in the safety of electric installations. Operation of the meter by unauthorized personnel may result in damage to the device and injury to the user.
- Using this manual does not exclude the need to comply with occupational health and safety regulations and with relevant fire regulations. Before starting work in special environments, e.g. with fire risks, explosive environments etc., always consult first with the person responsible for health and safety.
- Do not operate the meter:
 - If the meter is completely or partially malfunctioning.
 - If the meter has damaged test leads or insulation.
 - If the meter has been stored in adverse conditions (e.g. excessive humidity or heat).

If the meter is transferred from a cold to a warmer environment with high relative humidity do not perform measurements until the meter has been warmed up to the ambient temperature (approximately 30 minutes).

- Before starting any measurements make sure the test leads are connected to the appropriate measurement sockets and are fully inserted.
- Do not operate a meter with an open or partially closed battery compartment or power it from sources other than those specified.
- The meter's inputs are electronically protected from power surges, for example in the case of accidental connection to a power source, up to 276V for 30 seconds for all input combinations.
- Repairs must only be performed by Sonel or an authorized Sonel service center.
- The device complies with the following norms: EN 61010-1 and EN 61557-1, -4, -5.

Note:

The manufacturer reserves the right to modify the appearance, accessories and technical data of the meter.

Note:

An attempt to install drivers in 64-bit Windows 8 and Windows 10 may result in displaying "Installation failed" message.

Cause: Windows 8 and Windows 10 by default blocks drivers without a digital signature.

Solution: Disable the driver signature enforcement in Windows.

2 Menu

The menu is available at any position of the knob.

1



Press **MENU**.

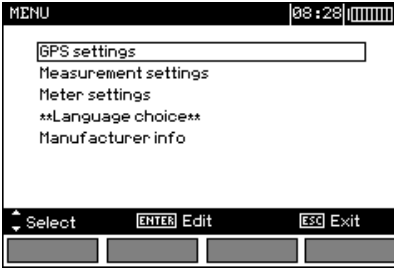

2

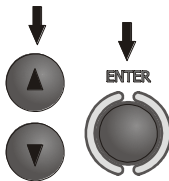

Using ▲ and ▼ buttons highlight the required position.
Press **ENTER** to select the option.

2.1 Wireless transmission

See chapter 5.3.

2.2 GPS settings

1

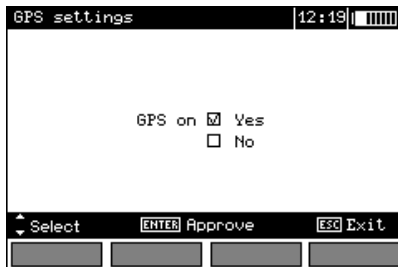

2

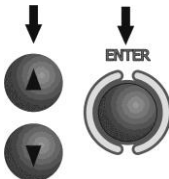



Using ▲, ▼ buttons select GPS on or off. Press **ENTER** to select the option.

Note:

- Enabling GPS during resistance (resistivity) measurement is indicated by the  icon in the left upper corner of the display. Searching GPS signal is indicated by the blinking icon. The icon stops blinking and is displayed continuously, when the satellite signal is found.

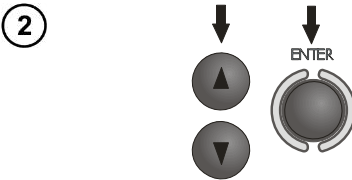
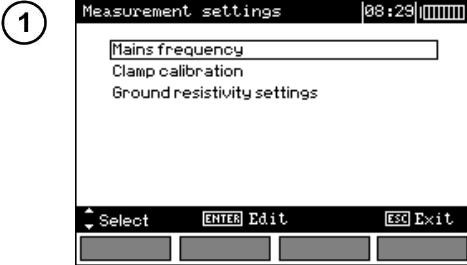
2.3 Measurement settings



Using  and  buttons highlight the required position.
Press **ENTER** to select the option.

2.3.1 Mains frequency

Before making any ground resistance measurements, the local mains frequency must be set in the meter since it is the source of potential interference with resistance measurements due to stray electrical fields. The meter will pick the appropriate frequency of its measurement signal to guarantee the optimum interference filtering. The meter is adapted for filtering of interference at 16 2/3Hz, 50Hz, 60Hz and 400Hz. The meter can automatically select the filtering parameter (selection of the mains frequency = AUTO), by running a series of measurements to determine the level of local interference prior to performing the earth resistance measurement. The AUTO function is active if the interference voltage is $\geq 1V$. Otherwise the meter adopts the last frequency value selected from the MENU.

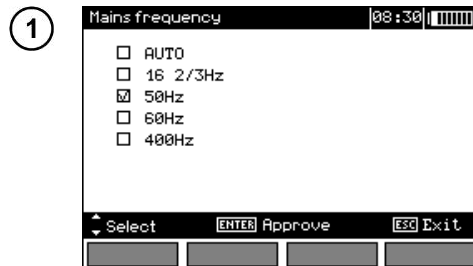

2

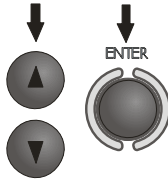

Using ▲ and ▼ buttons select the desired frequency and press **ENTER**.

2.3.2 Calibration of the current clamps

Current measurement is made using a rigid current clamp or flexible Rogowski current probe. The clamp or probe must be calibrated before using for the first time. It is advisable to periodically calibrate the clamp or probe so age effects will not influence the resolution of measurements. Re-calibrate again after a clamp or probe has been replaced.

Calibration of hard clamps

1



Select Clamp calibration in 2.3 above and press **ENTER**.

2

Follow the instructions.

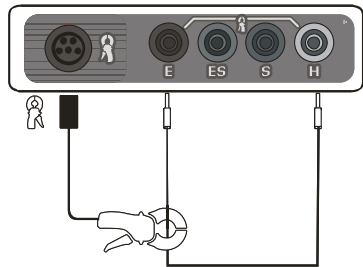

3

When calibration completes the display shows:



The meter has determined the calibration coefficients for the connected clamp or probe. This data is saved in the memory and is retained when the meter is switched off. In any subsequent calibration of a clamp or probe the calibration data will be updated.

Calibration of flexible clamps (using ERP-1 adapter)

1



After reading the introductory information press **ENTER**.

2

Follow on-screen prompts displayed by the meter and short H and E sockets with a wire.



3

Connect ERP-1 adapter to the terminal of the clamps.

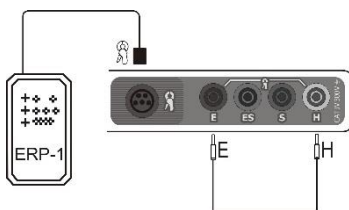

4



Turn ERP-1 adapter ON.

5

Connect flexible clamps to ERP-1 adapter.

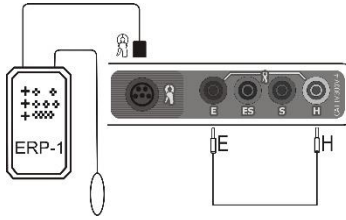

⑥ Wrap the clamps around the wire referred to in sec. ② (up to 4 times).

⑦ Use **FLEX** and **TURNS** buttons on ERP-1 adapter to select the clamps and number of wraps, according to the actual situation around the wire referred to in sec. ②.

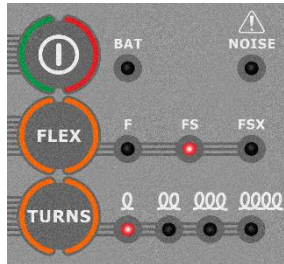

⑧ Press **START** button on MRU meter.

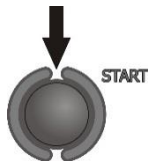

⑨ If the calibration is successful, you will see the following screen.



The meter has determined the correction factor for connected clamp. The factor is saved in the memory also when the power supply of the meter is off until the following successful calibration of the clamp has been performed.

Note:

- Make sure the test lead E – H passes through the center of the clamp or probe.

Additional information displayed by the meter

Message	Cause	Procedure
ERROR: CLAMP NOT CONNECTED OR NOT PUT ON WIRE CONNECTED TO H AND E SOCKET!	The clamp is not connected	Check whether the clamp is connected to the device or whether it is placed upon the test lead used by the meter to force the passage of current.
ERROR: WIRE NOT CONNECTED TO H AND E TERMINAL! CALIBRATION ABORTED. PRESS ENTER	No wire	Revise the connections
ERROR: CALIBRATION COEFFICIENT OUT OF RANGE. CALIBRATION ABORTED. PRESS ENTER	Incorrect calibration factor	Check the quality of the connections and/or replace the clamp.

2.3.3 Ground resistivity settings

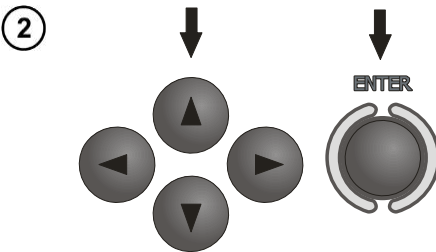
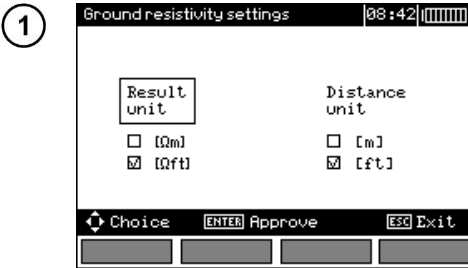

Using ▲, ▼, ◀ and ▶ buttons select the desired options for distance units and press **ENTER**.

2.4 Meter settings

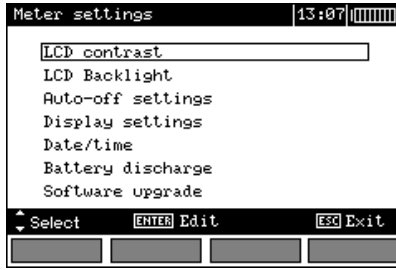

2.4.1 LCD contrast

Using ▲ and ▼ buttons set the contrast and press **ENTER**.

2.4.2 LCD Backlight

①

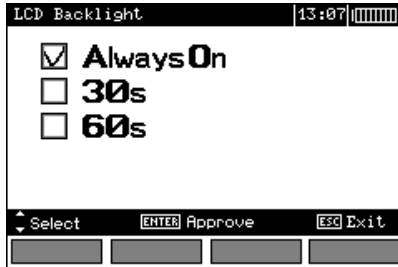

②

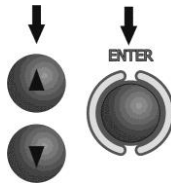

Use ▲, ▼ buttons to set the time for LCD backlight to remain on (Always) or shut-off time, and press **ENTER**.

2.4.3 AUTO-OFF settings

To set the automatic turn-off of the device use ▲ and ▼ buttons to set the display ON time, or AUTO-OFF disable, then press **ENTER**.

2.4.4 Display settings

To turn the Settings bar display that shows measurement parameters on or off use ▲ and ▼ buttons to select Yes or No, press **ENTER**.

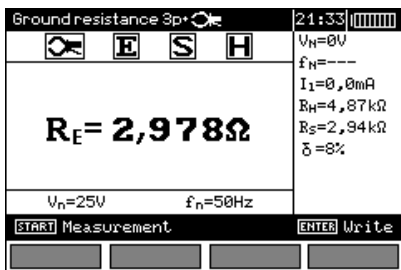

Visible Settings bar

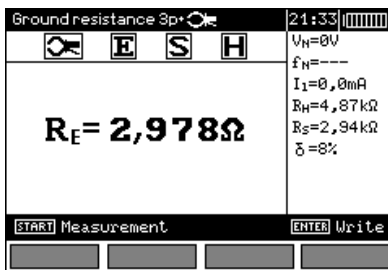

Hidden Settings bar

2.4.5 Date and time

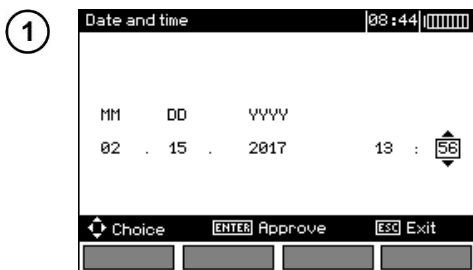

2

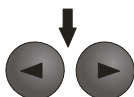

Use ◀ and ▶ buttons to change day, month, hour, or minute settings.

3

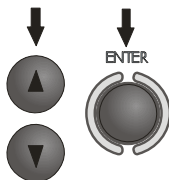

Use ▲ and ▼ buttons to set values. Once the date and time have been set press ENTER.

2.4.6 Battery discharge procedure

The procedure is fully described in chapter 6.5.

2.4.7 Software upgrade

NOTE!

Before updating the firmware charge the batteries.

Do not turn the meter off or disconnect the USB cable during the firmware update.

Before updating the meter firmware download the latest meter software version from www.sonel.pl or www.soneltest.com. Save the file in the computer in a known folder or location, and

then connect the meter to the computer. Select **Software upgrade** in the MENU and follow the on-screen instructions.

2.5 Language choice

- Use ▲ and ▼ buttons to select ****Language choice**** in the main MENU and press **ENTER**.
- Use ▲ and ▼ buttons to select the language and press **ENTER**.

2.6 Information on the manufacturer

Use ▲ and ▼ buttons in order to select **Product info** and press **ENTER**.

3 Measurements

Note:

During measurements the status bar is displayed.

3.1 Measurement of earth connection and equipotential bonding (2P)

Note:
The measurement complies with the requirements specified in the norm EN 61557-4 ($U < 24V$, $I > 200mA$ or $R \leq 10\Omega$).

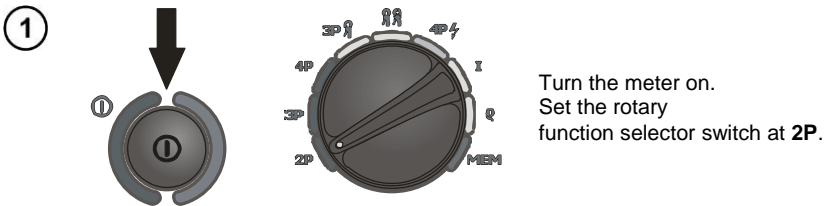

- ② Connect the earth ground system to be measured to the terminals **S** and **E** of the meter.

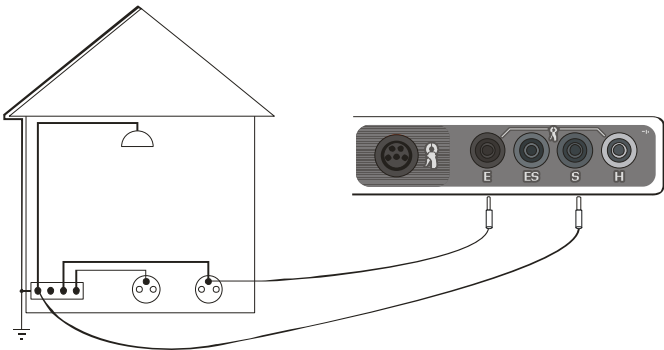

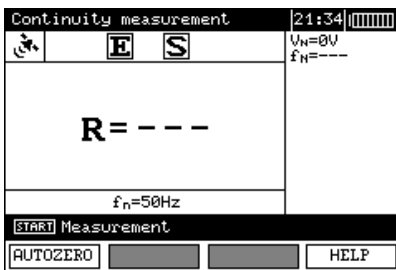

The meter is ready for measurement. The auxiliary display shows the value of the interference voltage and its frequency. The settings bar shows the mains frequency previously set in the MENU in 2.3.1 above.

3



Press **START** to begin the test.

4

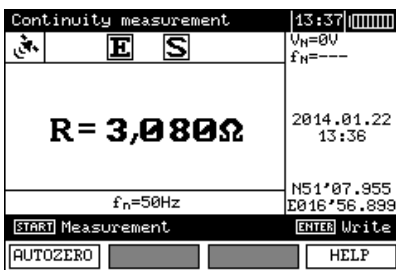

View the result. The right side of the display shows the date, time, and GPS coordinates.

The result is displayed for 20s. It may be displayed again by pressing **ENTER**.

Additional information displayed by the meter

R>19,99kΩ	Measurement range exceeded.
V_N>40V! and a continuous audio tone 	The voltage on the measurement points exceeds 40V, the measurement is cancelled.
V_N>24V!	The voltage on the measurement points exceeds 24V but lower than 40V, the measurement is cancelled.
NOISE!	The value of the interfering signal is too high, the result may be distorted by additional uncertainty.

3.2 Calibration of the test leads

In order to eliminate the resistance of the test leads, use the auto-zeroing function to compensate for test lead resistance. The measurement function **2P** includes the **AUTOZERO** sub-function.

3.2.1 Auto-zeroing on

1

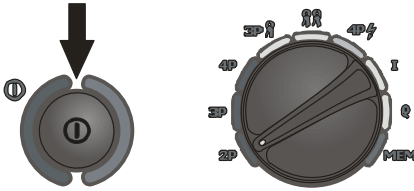

Turn the meter on.
Set the rotary function selector switch at **2P**.

2

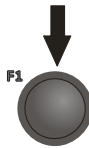

Press **F1**.

3

Follow the displayed instructions.

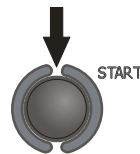
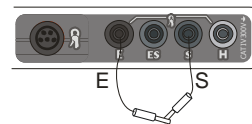
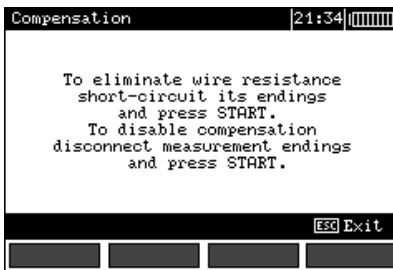

4

Once the auto-zero compensation has concluded the following will be displayed:



Auto-zeroing enabled is indicated by **AUTOZERO** shown on the right-hand side of the display.

3.2.2 Auto-zeroing off

①

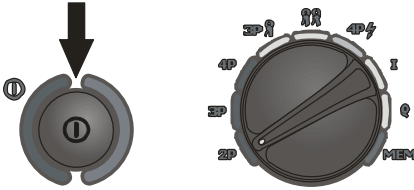

Turn the meter on.
Set the rotary
function selector switch at **2P**.

②

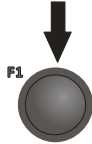

Press **F1**.

③

Separate the test leads. Press **START**.

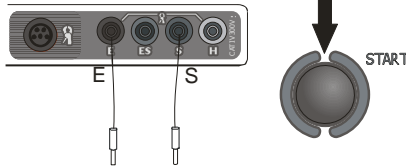

If auto-zero compensation is disabled, **AUTOZERO** will not be displayed on the right-hand side of the display.

Note:

- Auto-zero compensation needs only be enabled once for a given set of test leads. The last compensation values are remembered when the meter is turned off, until the next successful auto-reset procedure.

3.3 Measurement 3P

The basic kind of the earth resistance measurement is three-pole measurement.

①

Disconnect the earth ground electrode for the installation that is to be tested.

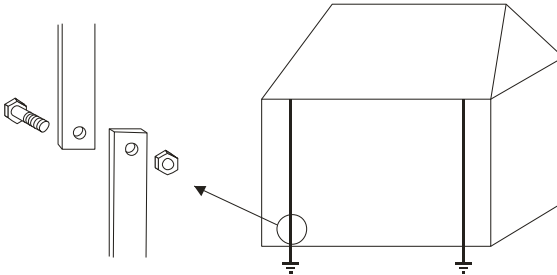

2

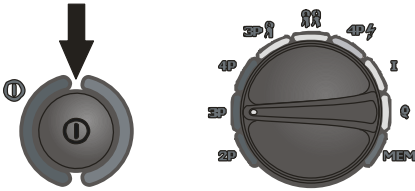

Turn the meter on.
Set the rotary
function selector switch at **3P**.

3

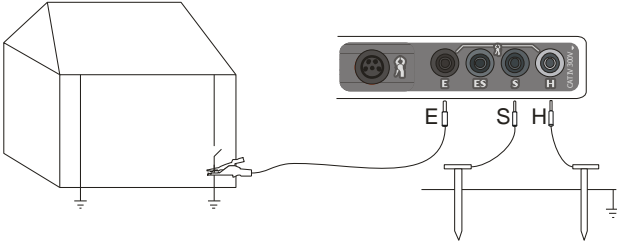

Drive the current probe into the ground and connect to the **H** socket of the meter.
Drive the voltage probe into the ground and connect to the **S** socket of the meter.
Connect the earth ground electrode under test to the **E** socket of the meter.
Align all electrodes in a straight line.

4

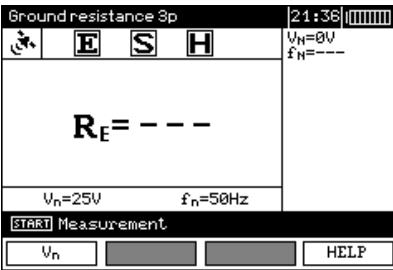

The meter is ready for measurement.
The auxiliary display shows the value of
the interference voltage and its frequency.
The settings bar shows the
mains frequency set in the MENU.

5

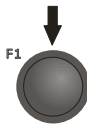

Press **F1** to select the measuring
voltage.

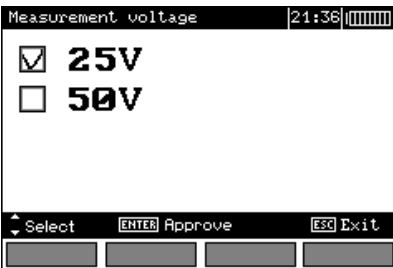

6

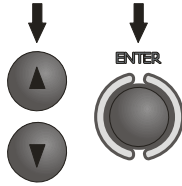

Use ▲ and ▼ buttons to set the measuring voltage and press **ENTER**.

7

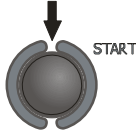

Press **START** to begin measurement.

8

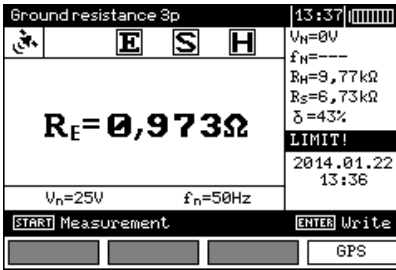

View the result.

Current probe resistance

Voltage probe resistance

Additional uncertainty caused by the resistance of the probes.

Displayed, when $\delta > 30\%$

By pressing the **F4** button you can display GPS coordinates.

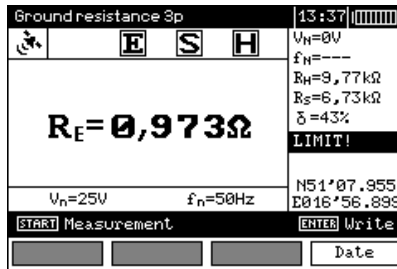

The result is displayed for 20s. It may be displayed again by pressing **ENTER**.

9

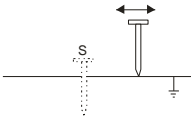

Repeat the measurements a few times (see points 3, 7 and 8) each time moving the voltage probe a few feet / a couple of meters, both to and away from the earth ground electrode under test. If after several measurements, the R_E test results differ more than 3%, then significantly increase the distance between the current probe from the earth electrode under test, and repeat the measurement procedure again.

Note:



Earth ground resistance measurement may be performed successfully if the interference voltage does not exceed 24V. The interference voltage is measured up to 100V, but over 50V it is signalled as hazardous. Do not connect the meter to a voltage exceeding 100V.

- Pay particular attention to the quality of the connection of the tested object with the test leads – the contact area must be cleaned of paint, rust, etc.
- If the resistance of the measurement probes is too high, then the measurement of earth ground resistance R_E will be affected by additional uncertainty. A particularly high measurement uncertainty occurs a low value of earth resistance is measured with probes with weak contact with the ground. (This situation can occur if the earth electrode is adequately driven into the ground but the upper layer of the ground is dry and characterized by a low conductivity. The relation between the probe resistance and the resistance of the measured earth ground will be high, leading to measurement uncertainty. In this situation, perform the testing in accordance with the formulae specified in point 10.2 which will permit evaluation of the influence of the measurement conditions. It is also possible to improve the contact of probes by moistening where the probe is driven, or driving probes into other locations, or using a longer 80 cm / 2.5 ft. probe. Check that the test leads are securely connected, the insulation is not damaged, and the probe contacts are not corroded or loose. In most cases measurements will be successful; however, be conscious of the sources of uncertainty the measurement can be affected by.
- If the resistance of both **H** and **S** probes or one of them exceeds 19,9k Ω , the meter displays the message: " **R_H and R_s electrodes resistance are higher than 19.9 k Ω ! Measurement impossible!**".
- Manufacturer's calibration doesn't include the resistance of test leads. Displayed result is sum of measured object and test leads resistance.

Additional information displayed by the meter

$R_E > 19,99k\Omega$	Measurement range exceeded.
$V_N > 40V!$ and a continuous audio tone 	The voltage on the measurement points exceeds 40V, the measurement is cancelled.
$V_N > 24V!$	The voltage on the measurement points exceeds 24V but lower than 40V, the measurement is cancelled.
LIMIT!	The uncertainty of the electrode resistance > 30%. (Uncertainties calculated on the basis of the measured values)
NOISE!	The value of the interfering signal is too high, the result may be distorted by additional uncertainty.

3.4 Measurement 4p

The four-pole method is recommended in the case of measurements of earth ground resistance of very low values. It eliminates the influence of test lead resistance on the result of the measurement. To evaluate the earth ground resistance, measurements are repeated as described in section 3.9.

- 1 Disconnect the tested earth electrode for the object installation.

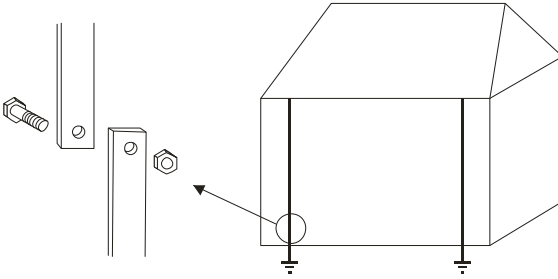

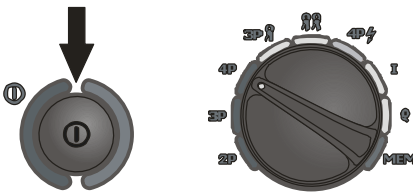
- 2  Turn the meter on.
Set the rotary function selector switch at **4P**.

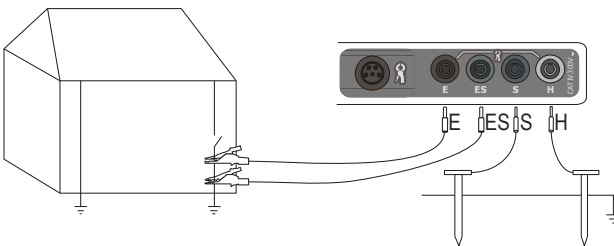
- 3  Drive the current probe into the ground and connect to the **H** socket of the meter.
Drive the voltage probe into the ground and connect to the **S** socket of the meter.
Connect the earth ground electrode under test to the **E** socket of the meter.
Connect the **ES** socket to the earth ground electrode under test below the **E** cable.
Align all electrodes in a straight line.

4

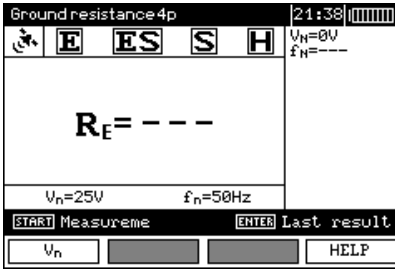

The meter is ready for measurement. The auxiliary display shows the value of the interference voltage and its frequency. The settings bar shows the mains frequency set in the MENU.

5

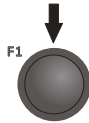

Press **F1** to select the measuring voltage.

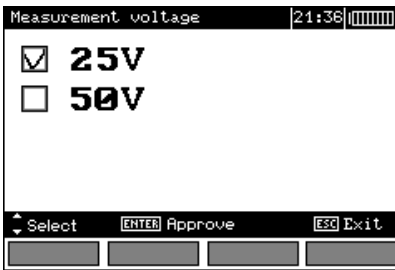

6

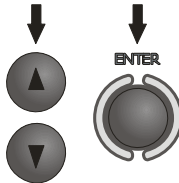

Use \blacktriangle and \blacktriangledown buttons to set the measuring voltage and press **ENTER**.

7

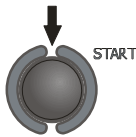

Press **START** to begin measurement.

8

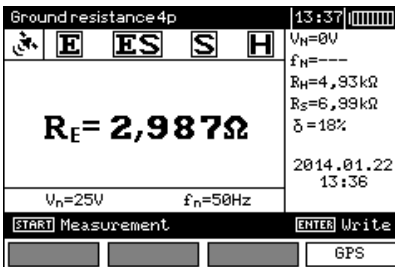

View the result.

- \blacktriangleleft Current probe resistance
- \blacktriangleleft Voltage probe resistance
- \blacktriangleleft Additional uncertainty caused by the resistance of the probes.

By pressing the **F4** button you can display GPS coordinates.

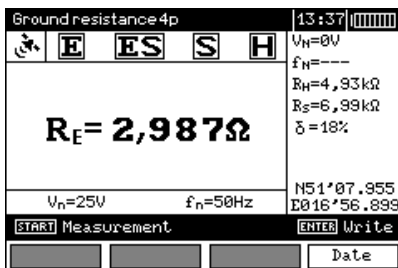

The result is displayed for 20s. It may be displayed again when **ENTER** is pressed.

9

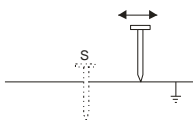

Repeat the measurements a few times (see points 3, 7 and 8) each time moving the voltage electrode a few feet / a couple of meters, both to and away from the tested earth ground electrode. If after several R_E tests the results differ more than 3%, then significantly increase the distance between the current electrode from the earth electrode under test, and repeat the measurement procedure again.

Note:



Earth ground resistance measurement may be performed successfully if the interference voltage does not exceed 24V. The interference voltage is measured up to 100V, but over 50V is it signalled as hazardous. Do not connect the meter to a voltage exceeding 100V.

- Pay particular attention to the quality of the connection of the tested object with the test leads – the contact area must be cleaned of paint, rust, etc.
- If the resistance of the measurement probes is too high, then the measurement of earth ground resistance R_E will be affected by additional uncertainty. A particularly high measurement uncertainty occurs a low value of earth resistance is measured with probes with weak contact with the ground. (This situation can occur if the earth electrode is adequately driven into the ground but the upper layer of the ground is dry and characterized by a low conductivity. The relation between the probe resistance and the resistance of the measured earth ground will be high, leading to measurement uncertainty. In this situation, perform the testing in accordance with the formulae specified in point 10.2 which will permit evaluation of the influence of the measurement conditions. It is also possible to improve the contact of probes by moistening where the probe is driven, or driving probes into other locations, or using a longer 80 cm / 2.5 ft. probe. Check that the test leads are securely connected, the insulation is not damaged, and the probe contacts are not corroded or loose. In most cases measurements will be successful; however, be conscious of the sources of uncertainty the measurement can be affected by.
- If the resistance of both **H** and **S** probes or one of them exceeds 19,9kΩ, the meter displays the message: " **R_H and R_S electrodes resistance are higher than 19.9 kΩ! Measurement impossible!**".
- Manufacturer's calibration doesn't include the resistance of test leads. Displayed result is sum of measured object and test leads resistance.

Additional information displayed by the meter

RE>19,99kΩ	Measurement range exceeded.
V_N>40V! and a continuous audio tone 	The voltage on the measurement points exceeds 40V, the measurement is cancelled.
V_N>24V!	The voltage on the measurement points exceeds 24V but lower than 40V, the measurement is cancelled.
LIMIT!	The uncertainty of the electrode resistance > 30%. (Uncertainties calculated on the basis of the measured values)
NOISE!	The value of the interfering signal is too high, the result may be distorted by additional uncertainty.

3.5 Measurement 3p + clamp

1

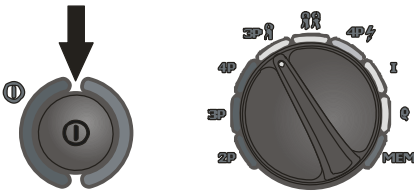

Turn the meter on.
Set the rotary function selector switch at **3P Ω**.

2

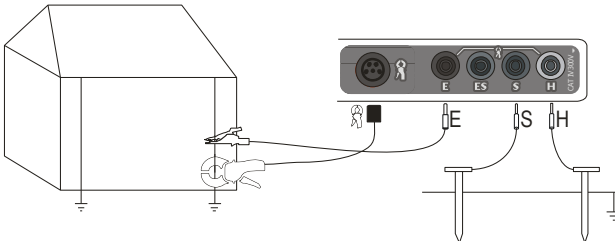

Drive the current probe into the ground and connect to the **H** socket of the meter.
Drive the voltage probe into the ground and connect to the **S** socket of the meter.
Connect the earth ground electrode under test to the **E** socket of the meter.
Align all electrodes in a straight line.
Position the current clamp on the earth ground electrode under test below the **E** cable connection.

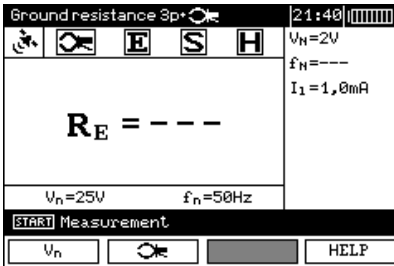

The meter is ready for measurement.
The auxiliary display shows the value of the interference voltage and its frequency. The settings bar shows the mains frequency set in the MENU.

3

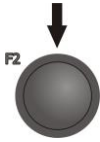

Press button **F2** to select measurement with a C-3 current clamp.

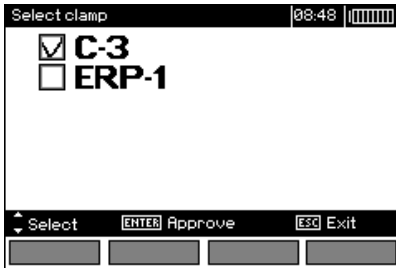

4

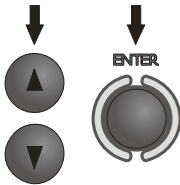

Use ▲ and ▼ buttons to select C-3 clamp and press **ENTER**.

5

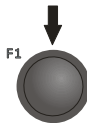

Press **F1** to select the measuring voltage.

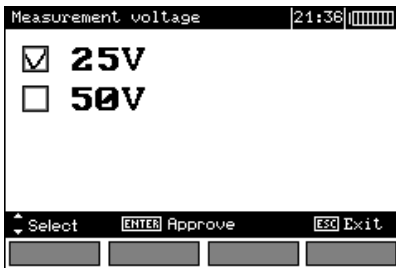

6

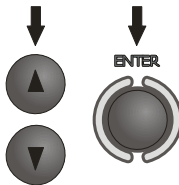

Use ▲ and ▼ buttons to set the measuring voltage and press **ENTER**.

7

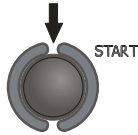

Press **START** to begin measurement.

8

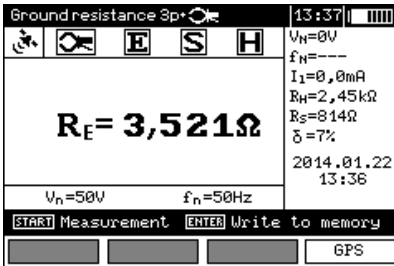

View the result.

- ← Current probe resistance
- ← Voltage probe resistance
- ← Additional uncertainty caused by the resistance of the probes.

Press the **F4** button to display GPS coordinates.

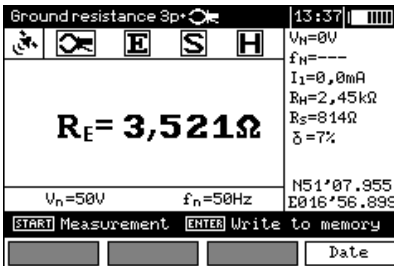

The result is displayed for 20s.

It may be displayed again when **ENTER** is pressed.

9

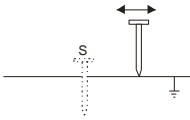

Repeat the measurements a few times (see points 2 and 5) each time moving the voltage probe a few feet / a couple of meters, both to and away from the tested earth ground electrode. If after several R_E tests the results differ more than 3%, then significantly increase the distance between the current electrode from the earth electrode under test, and repeat the measurement procedure again.

Notes:

⚠

Flexible Rogowski current probes must not be used for this measurement.



Earth ground resistance measurement may be performed successfully if the interference voltage does not exceed 24V. The interference voltage is measured up to 100V, but over 50V is it signalled as hazardous. Do not connect the meter to a voltage exceeding 100V.

- Current clamps and probes are not provided as standard accessories and must be purchased separately.
 - Current clamps and probes must be calibrated before use. Calibrate each clamp or probe periodically to avoid the influence of component ageing upon the resolution of measurements. The calibration option is in the **MENU**.
- Pay particular attention to the quality of the connection of the tested object with the test leads – the contact area must be cleaned of paint, rust, etc.
- If the resistance of the measurement probes is too high, then the measurement of earth ground resistance R_E will be affected by additional uncertainty. A particularly high measurement uncertainty occurs a low value of earth resistance is measured with probes with weak contact with the ground. (This situation can occur if the earth electrode is adequately driven into the ground but the upper layer of the ground is dry and characterized by a low conductivity. The relation between the probe resistance and the resistance of the measured earth ground will be high, leading to measurement uncertainty. In this situation, perform the testing in accordance with the formulae specified in point 10.2 which will permit evaluation of the influence of the measurement conditions. It is also possible to improve the contact of probes by moistening where the probe is driven, or driving probes into other locations, or using a longer 80 cm / 2.5 ft. probe. Check that the test leads are securely connected, the insulation is not damaged, and the probe contacts are not corroded or loose. In most cases measurements will be successful; however, be conscious of the sources of uncertainty the measurement can be affected by.
 - If the resistance of both **H** and **S** probes or one of them exceeds 19,9k Ω , the meter displays the message: " **R_H and R_S electrodes resistance are higher than 19.9 k Ω ! Measurement impossible!**".
 - Manufacturer's calibration doesn't include the resistance of test leads. Displayed result is sum of measured object and test leads resistance.

Additional information displayed by the meter

$R_E > 1999\Omega$	Measurement range exceeded.
$V_N > 40V!$ and a continuous audio tone 	The voltage on the measurement points exceeds 40V, the measurement is cancelled.
$V_N > 24V!$	The voltage on the measurement points exceeds 24V but lower than 40V, the measurement is cancelled.
NOISE!	The value of the interfering signal is too high, the result may be distorted by additional uncertainty.
LIMIT!	The uncertainty of the electrode resistance > 30%. (Uncertainties calculated on the basis of the measured values)
$I_L > \max$	Excessive interfering current, the measurement error may exceed the basic error

3.6 Measurement 3p + ERP-1 adapter

1

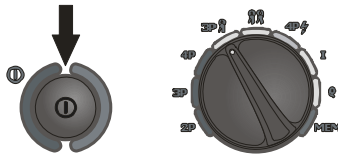

Turn the meter on.
Set the rotary function selector switch at **3P**.

2

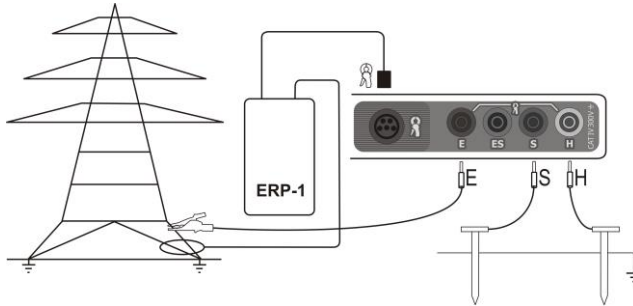

Drive the current probe into the ground and connect to the **H** socket of the meter.
Drive the voltage probe into the ground and connect to the **S** socket of the meter.
Connect the first leg of the pylon to be tested to the **E** socket of the meter.
Align the leg of the pylon under test, the current electrode, and the voltage electrode in a straight line.
Attach the current probe around the pylon leg under test below the connection point of **E** as shown.

3

Select voltage measurement as described in par. 3.5.

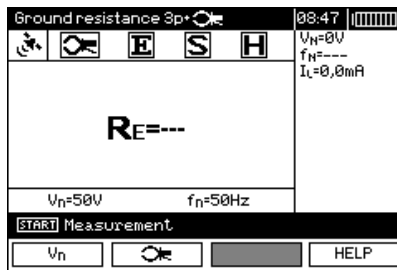

4

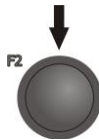

Press **F2** button to select the measurement for ERP-1.

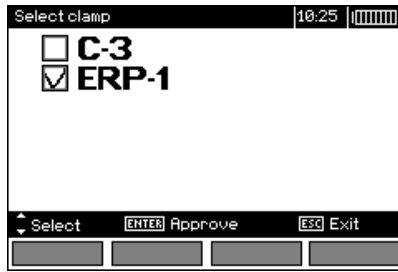

5

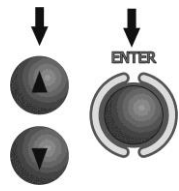

Use ▲, ▼ buttons to select the measurement with ERP-1, press **ENTER**.

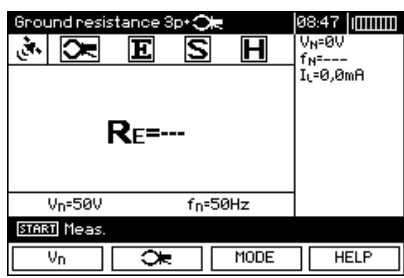

6

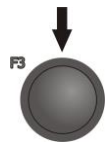

Press **F3** button to select the number of pylon legs.

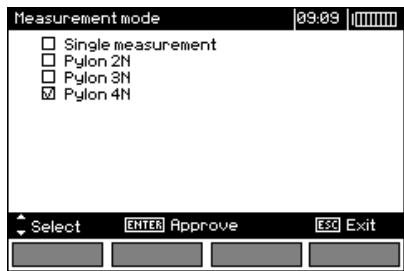

7

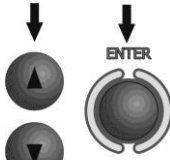

Use ▲, ▼ buttons to select the number of pylon legs, press **ENTER**.

8

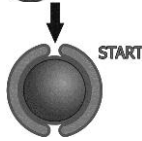

Press **START**. Follow the command on the screen and position the current probe around the first leg of the pylon (if not already done).

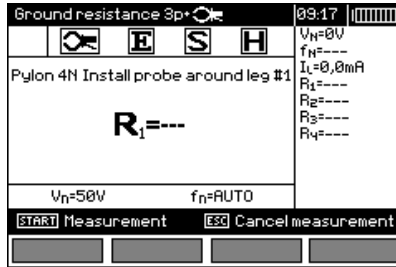

9

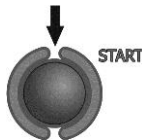

To start the measurement, press **START** again.

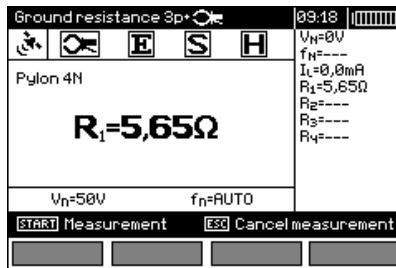

After the measurement of the first leg of the pylon, the measured resistance value of the tested leg is shown on the main screen as R1. After 5 seconds the meter transfers the R1 result to the window on the right side of the display and displays a message to attach the current probe around the next leg of the pylon.

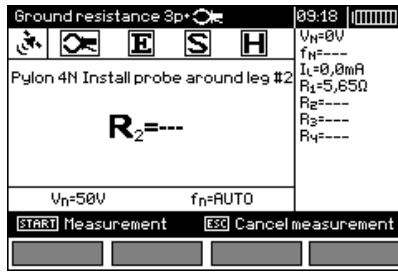

The last result may be restored on the display for another 5 seconds by pressing **ENTER**.

- ⑩ After performing the measurement on the last leg of the pylon the meter displays the last result for 5 seconds, the meter will then display the resultant earth resistance R_E .

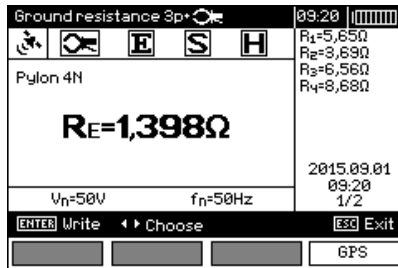

Use buttons ◀ and ▶ to change results displayed in the window on the right side of the screen.

3.7 Two-clamp measurement

Two-clamp measurements are used where there is no possibility of using ground-driven electrodes.

NOTE!

The two-clamp method may be used solely in the case of multiple earthing measurements.

①

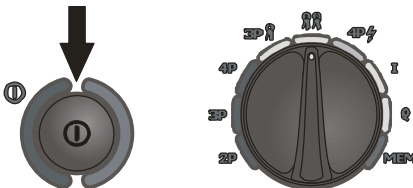

Turn the meter on.
Set the rotary function selector switch at .

2

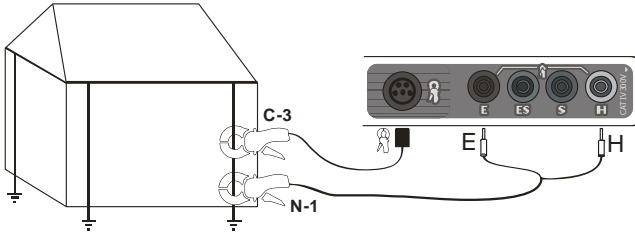

Connect the transmission clamp to sockets **H** and **E**. The measurement clamp should be connected to the clamp socket.

Attach both the transmission clamp and the measurement clamp on the earth ground electrode under test at least 1 ft. / 30cm from each other as shown.

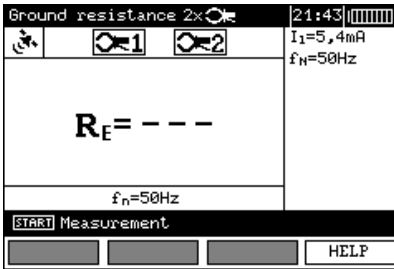

The meter is ready for measurement. The auxiliary display shows the value of the leakage current passing through the measurement clamp with split core (C-3) and its frequency.

3

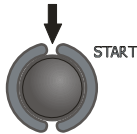

Press **START** to begin measurement.

4

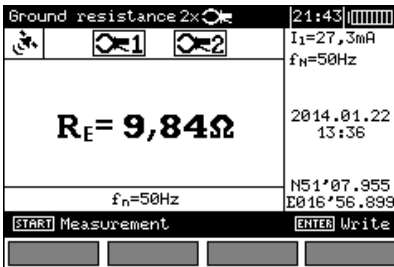

View the result.

The result is displayed for 20s. It may be displayed again when **ENTER** is pressed.

Notes:



Measurements may be performed in the presence of interference current not exceeding 3A rms and whose frequency complies with the value set in the MENU.



Flexible Rogowski current probe must not be used for this measurement.

- Current clamps and probes are not provided as standard accessories and must be purchased separately.
- Current clamps and probes must be calibrated before use. Calibrate each clamp or probe periodically to avoid the influence of component ageing upon the resolution of measurements. The calibration option is in the **MENU**.
- If the clamp current is insufficient, an appropriate message is displayed: "**Measured current is too low. Measurement impossible!**".

Additional information displayed by the meter

RE>149,9Ω	Measurement range exceeded.
V_N>40V! and a continuous audio tone. ↕	The voltage on the measurement points exceeds 40V, the measurement is cancelled.
V_N>24V!	The voltage on the measurement points exceeds 24V but lower than 40V, the measurement is cancelled.
NOISE!	The value of the interfering signal is too high, the result may be distorted by additional uncertainty.

3.8 Measurement 4P[‡] (Impulse method)

The impulse method is applied in the case of measurement of the dynamic impedance of lightning arrester earthing systems. It must not be used for the purpose of measurements of protective and working earthing systems.

Due to the high steepness of the test pulse leading edge the inductivity of the earth electrode highly influences its impedance. Therefore the impedance of the earth electrode measured by means of the impulse method depends upon its length and the steepness of the test pulse leading edge.

The inductivity of the earth electrode causes a shift between the current spikes and the resultant voltage drop. Hence extensive earth electrodes of a low resistance measured by means of the low-frequency method may have a much higher value of the dynamic impedance.

The impulse impedance is calculated on the basis of the following formula:

$$Z_E = \frac{V_S}{I_S}$$

Where V_S , I_S – peak value of the current and voltage.

The impulse method is used to determine the resultant earth impedance. Therefore the control measurement points must not be undone.

Note:

Measuring leads must be completely unwound. Otherwise the result of the measurement may be incorrect.

The following illustration explains the numbers which determine the shape of the pulse (in accordance with EN 62305-1 Lightning protection – Section 1. General Requirements).

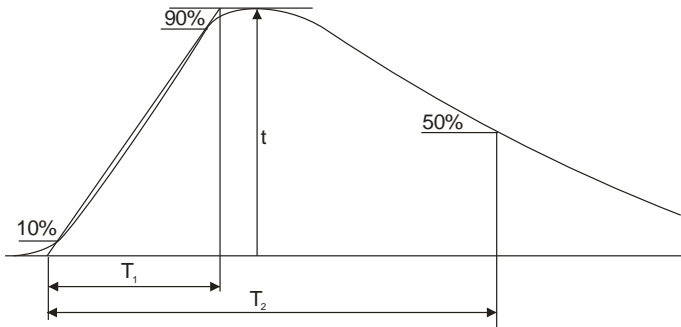

t = current amplitude
 T_1 = pulse leading edge duration
 T_2 = time to semi-spike

The pulse shape is determined by the relation T_1/T_2 eg: $4/10\mu s$.

1

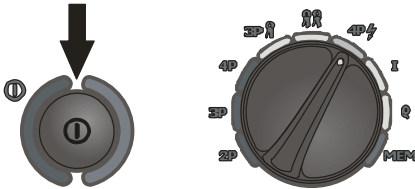

Turn the meter on.
 Set the rotary
 function selector switch at **4P**.

2

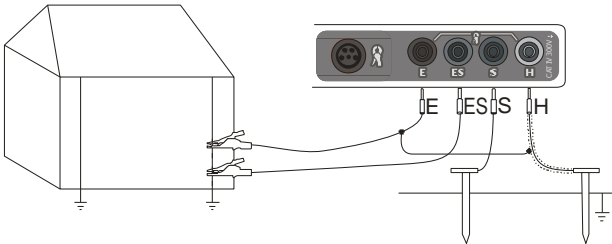

Drive the current probe into the ground and connect to the **H** socket of the meter.
 Drive the voltage probe into the ground and connect to the **S** socket of the meter.
 Connect the earth ground electrode under test to the **E** socket and the shield of
 the **H** cable as shown.

Connect the earth ground electrode under test to the **ES** socket below the **E**
 cable as shown.

It is recommended to place the test leads in such a manner that the angle be-
 tween them is at least **60°** - see diagram below.

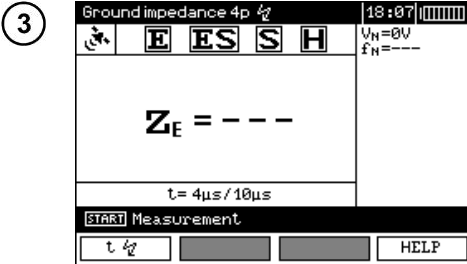
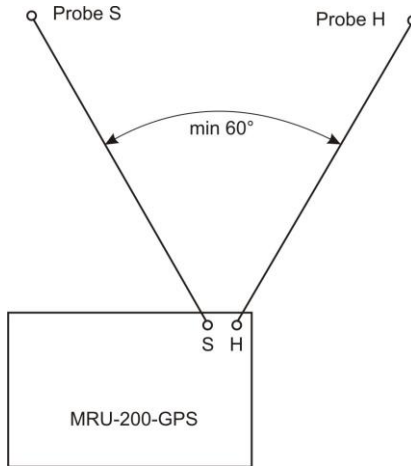

The meter is ready for measurement. The auxiliary display shows the value of the interference voltage and its frequency. The settings bar shows the pulse shape; i.e. rise-time and duration.



Press **F1** to modify the pulse shape.

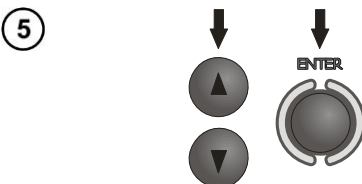
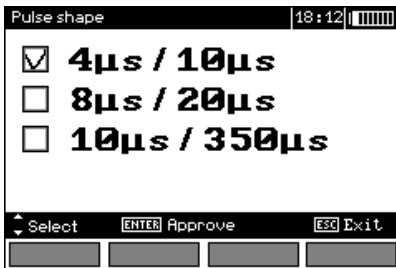

Use buttons ▲ and ▼ to select the pulse shape and press **ENTER**.

6

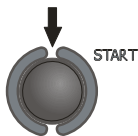

Press **START** to begin measurement.

7

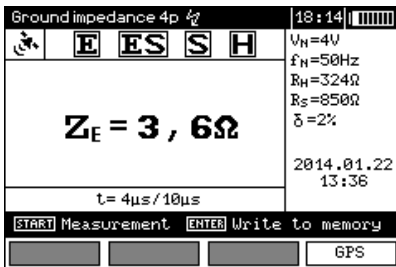

View the result.

- ← Current probe resistance
- ← Voltage probe resistance
- ← Additional uncertainty caused by the resistance of the probes.

By pressing the **F4** button you can display GPS coordinates.

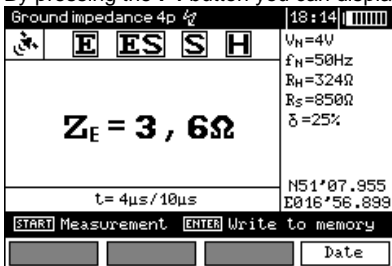

The result is displayed for 20s. It may be displayed again when **ENTER** is pressed.

Notes:

⚠

Earth ground resistance measurement may be performed successfully if the interference voltage does not exceed 24V. The interference voltage is measured up to 100V, but over 50V is it signalled as hazardous. Do not connect the meter to a voltage exceeding 100V.

- Pulse shape 8/20 μs is available from firmware version 2.04.

- R_H i R_S are measured by means of the low-frequency method.

Pay particular attention to the quality of the connection of the tested object with the test leads – the contact area must be cleaned of paint, rust, etc.

- If the resistance of the measurement probes is too high, then the measurement of earth ground resistance R_E will be affected by additional uncertainty. A particularly high measurement uncertainty occurs a low value of earth resistance is measured with probes with weak contact with the ground. (This situation can occur if the earth electrode is adequately driven into the ground but the upper layer of the ground is dry and characterized by a low conductivity. The relation between the probe resistance and the resistance of the measured earth ground will be high, leading to measurement uncertainty. In this situation, perform the testing in accordance with the formulae specified in point 10.2 which will permit evaluation of the influence of the measurement conditions. It is also possible to improve the contact of probes by moistening where the probe is driven, or driving probes into other loca-

tions, or using a longer 80 cm / 2.5 ft. probe. Check that the test leads are securely connected, the insulation is not damaged, and the probe contacts are not corroded or loose. In most cases measurements will be successful; however, be conscious of the sources of uncertainty the measurement can be affected by.

- If the resistance of **H** and **S** probes or one of them exceeds 1k Ω , an appropriate message is displayed: "**R_H and R_S electrodes resistance are higher than 1 k Ω ! Measurement impossible!**".

Additional information displayed by the meter

Z_E>199Ω	Measurement range exceeded.
V_N>40V! and a continuous audio tone. ⏮	The voltage on the measurement points exceeds 40V, the measurement is cancelled.
V_N>24V!	The voltage on the measurement points exceeds 24V but lower than 40V, the measurement is cancelled.
LIMIT!	The uncertainty of the electrode resistance > 30%. (Uncertainties calculated on the basis of the measured values)
NOISE!	The value of the interfering signal is too high, the result may be distorted by additional uncertainty.

3.9 Current measurement

The current measurement function simply measures current with a current clamp or probe. It may be used for example for measurement of leakage current in an installation. Sonel offers several types of clamps and probes, with various diameters and current ranges (see Technical Data).

1

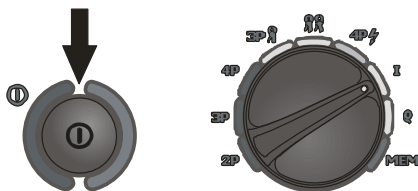

Turn the meter on.
Set the rotary function selector switch at **I**.

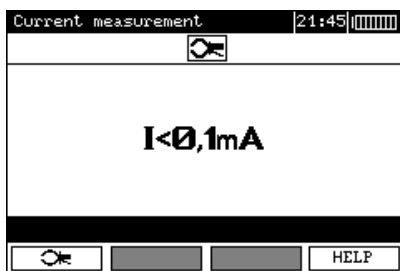

2

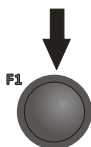

Press **F1** to select type of clamp.

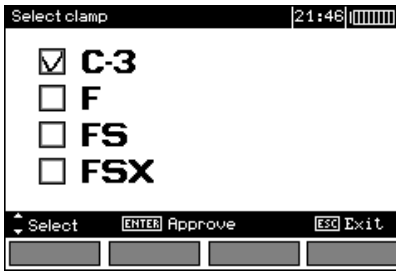

3

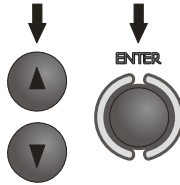

Use buttons ▲ and ▼ to select the type of clamp and press **ENTER**.

Notes:

- Current measurements are continuous and there is no possibility of them being saved.
- Flexible Rogowski current probe F-1 is used for measurement of current > 1A.

3.10 Earth resistivity measurements

Earth resistivity measurements ρ are used to make preliminary measurements for the design of earth ground system installations, or for geological studies. The function is metrologically identical to the four-pole earth ground resistance measurement, but includes an additional procedure for storing the distance between the electrodes. The result gives the resistivity value which is calculated automatically in accordance with the following formula: $\rho = 2\pi LR_E$, (Wenner's measurement method.) The method assumes equal distances between electrodes.

1

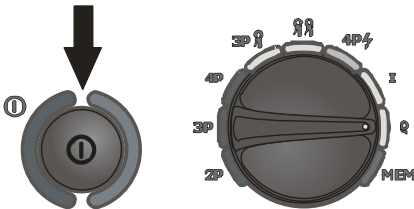

Turn the meter on.
Set the rotary function selector switch at ρ .

2

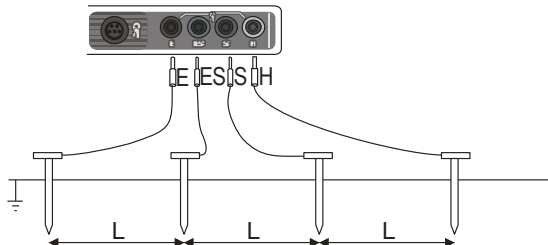

Drive four probes, equally spaced and in a straight line, into the ground. Connect all 4 probes to the meter, as shown above.

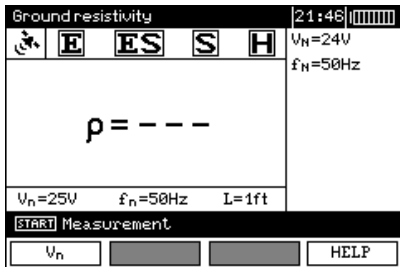

The meter is ready for measurement. The auxiliary display shows the value of the interference voltage and its frequency. The settings bar shows the measurement voltage, mains frequency set in the **MENU**, and the distance between the electrodes.

3

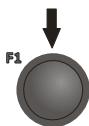

Press **F1** to change the measurement voltage.

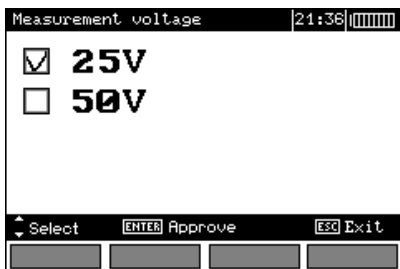

4

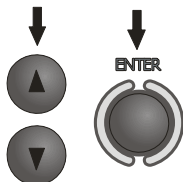

Use ▲ and ▼ buttons to select the measuring voltage and press **ENTER**.

5

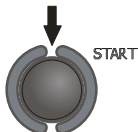

Press **START** to begin measurement. The meter display will first request selecting of the distance between probes.

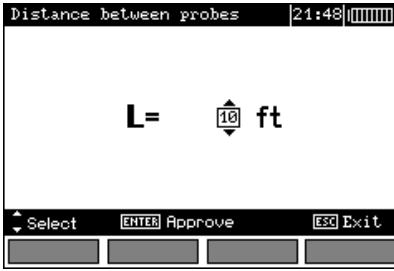

6

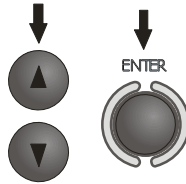

Use buttons ▲ and ▼ to set the distance between probes and press **ENTER** to begin measurement.

7

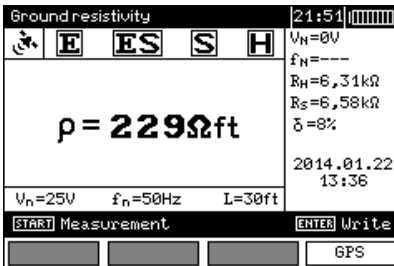

View the result.

- ← Current probe resistance
- ← Voltage probe resistance
- ← Additional uncertainty caused by the resistance of the probes

By pressing the **F4** button you can display GPS coordinates.

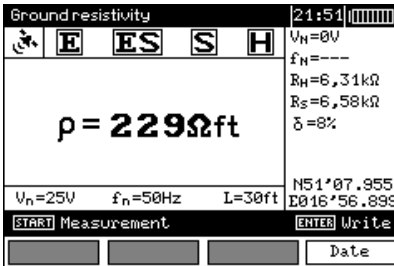

The result is displayed for 20s. It may be displayed again when **ENTER** is pressed.

Notes:

⚠

Earth ground resistance measurement may be performed successfully if the interference voltage does not exceed 24V. The interference voltage is measured up to 100V, but over 50V it is signalled as hazardous. Do not connect the meter to a voltage exceeding 100V.

- Calculations are based upon the assumption that the distance between the measurement electrodes are equal (Wenner's method). If this is not the case, the earth ground resistance measurement must be performed by the four-pole method, and calculations must be performed individually. Pay particular attention to the quality of the connection of the tested object with the test leads – the contact area must be cleaned of paint, rust, etc.
- If the resistance of the measurement probes is too high, then the measurement of earth ground resistance R_E will be affected by additional uncertainty. A particularly high measurement uncertainty occurs a low value of earth resistance is measured with probes with weak contact with the ground. (This situation can occur if the earth electrode is adequately driven into the ground but the upper layer of the ground is dry and characterized by a low conductivity. The relation between the probe resistance and the resistance of the measured earth ground will be high, leading to measurement uncertainty. In this situation, perform the testing in accordance with the formulae specified in point 10.2 which will permit evaluation of the influence of the measurement conditions. It is also possible to improve the contact of probes by moistening where the probe is driven, or driving probes into other locations, or using a longer 80 cm / 2.5 ft. probe. Check that the test leads are securely connected, the insulation is not damaged, and the probe contacts are not corroded or loose. In most cases measurements will be successful; however, be conscious of the sources of uncertainty the measurement can be affected by.
- If the resistance of **H** and **S** probes or one of them exceeds 19,9k Ω , an appropriate message is displayed: "**R_H and R_S electrodes resistance are higher than 19.9 k Ω ! Measurement impossible!**".

Additional information displayed by the meter

$\rho > 999k\Omega m$	Measurement range exceeded.
$V_N > 40V!$ and a continuous audio tone. ⚡	The voltage on the measurement points exceeds 40V, the measurement is cancelled.
$V_N > 24V!$	The voltage on the measurement points exceeds 24V but lower than 40V, the measurement is cancelled.
LIMIT!	The uncertainty of the electrode resistance > 30%. (Uncertainties calculated on the basis of the measured values)
NOISE!	The value of the interfering signal is too high, the result may be distorted by additional uncertainty.

4 Memory

The MRU-200-GPS meters are equipped with a memory to store up to 990 results of resistance measurements. Individual measurements are saved in memory cells. The memory is divided into 10 banks of 99 cells each. Each result may be saved in a cell of a defined number, and in a selected bank. The user may assign numbers of the cells to individual measurement points, and the numbers of the banks to individual objects, perform measurements in any order, and repeat them without losing other data.

The memory is not deleted when the meter is turned off, so results may be saved and reviewed at a later time, or transmitted to a computer.

It is good practice to delete the memory before a new series of measurements is performed, making sure that before memory is erased the data has been reviewed and retained if necessary, usually by saving on a computer.

4.1 Saving measurement results in the memory

1



Once the measurement has finished press **ENTER**.

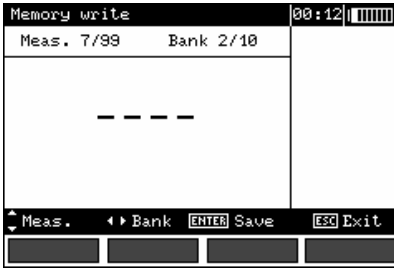

Empty cell

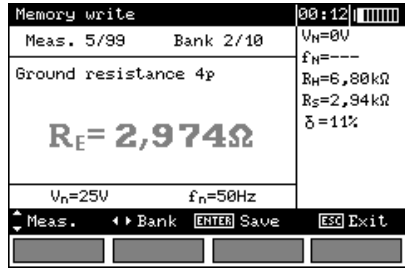

Occupied cell

2

Cells are selected via the ▲ and ▼ buttons. Banks are selected via the ◀ and ▶ buttons. To save press **ENTER**.

3

If the cell is occupied, the following message will be displayed:

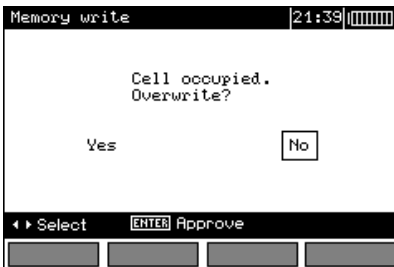

4

Once the option has been selected with the ◀ and ▶ buttons and press **ENTER**.

4.2 Erasing Memory

Note:

- During the process of erasing memory the progress bar is displayed.

①

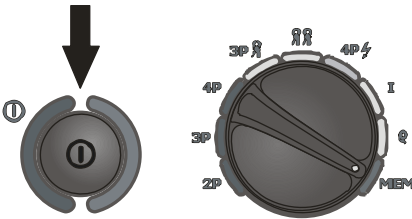

Turn the meter on.
Set the rotary
function selector switch at **MEM**.

②



Using the ▲ and ▼ buttons highlight
“Erasing memory”.

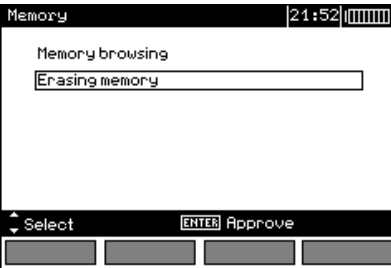

③



Press **ENTER**.



4



Use the ▲ and ▼ buttons to select either "All memory erase", "Erase bank" or "Erase measurement"

5

Follow the instructions on the display.

4.3 Memory browsing

1



Use the ▲ and ▼ buttons to highlight "Memory browsing".

2



Press **ENTER**.

Memory browsing		00:30
Meas. 5/7	Bank 2/2	V _N =0V
Continuity measurement		f _N ---
R = 2,983Ω		R _H =6,80kΩ
		R _S =2,94kΩ
		δ = 11%
V _n =25V	f _n =50Hz	
Measurement		Exit

3

Use the ◀ and ▶ buttons to select a bank and the ▲ and ▼ buttons to select a cell.

Note:

- During a memory search only those cells that contain data are listed; empty cells and banks are skipped and are not viewable. "Meas. 1/20" means the first measurement in a group of 20; cells 21 to 99 are empty. The same principle refers to banks. If the memory is not filled in a continuous manner, then empty measurements and banks are skipped during browsing.

5 Data transmission

Remarks:

- Data transmission is not possible during the charging of the batteries.

5.1 Computer connection accessories

The meter can be connected to a computer via the supplied USB cable, using the Sonel Reader software. The software can also be downloaded from www.soneltest.com or www.sone.pl.

5.2 Connection of the meter to a computer

1. Set the rotary function selector switch at MEM.
2. Connect the cable to the USB port of the computer and the USB socket of the meter.
3. Run the software Sonel Reader on the computer.

5.3 Data transmission with Bluetooth module

1. Select **Wireless transmission** in the main MENU of the meter.

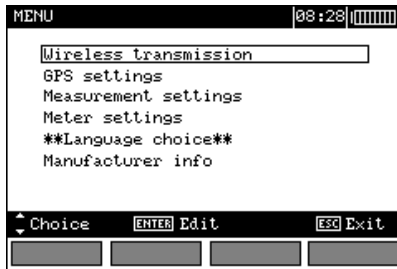

or set the function switch to **MEM** and press **F1**.



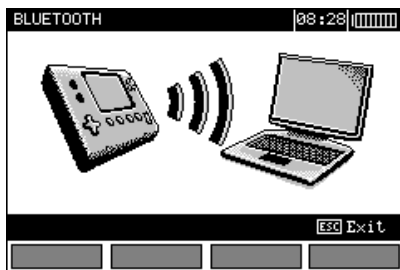

2. Connect Bluetooth module to the USB socket of the PC, unless it is integrated into the PC.
3. During the process of pairing the meter with a PC enter PIN code compatible with the PIN code of the meter defined in main settings.
4. On the computer start data storing programme.

If a PIN code change is necessary, select **Modify PIN code**.



Set the required code with the cursors.

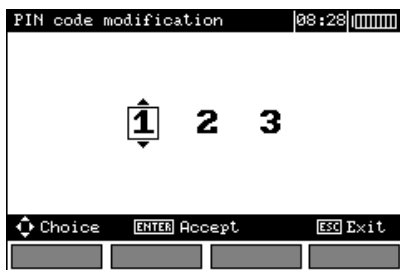

Note:



Standard pin for Bluetooth is "123".

- The data transmission may be interrupted using the **ESC** button.
- With the USB cable active the wireless transmission is not possible.

6 Power supply

Note:

The MRU-200-GPS has been designed for use only with the supplied rechargeable batteries. Using disposable instead of rechargeable batteries should take place only in emergency situations when the rechargeable batteries are depleted. However, disposable batteries will discharge rapidly after several measurements, which should be expected due to the high instantaneous power consumption of the instrument.

6.1 Monitoring of the power supply voltage

The level of the charge of the batteries indicated by the symbol in the right upper corner of the display:



Battery charged.

Battery low.

Battery fully discharged.

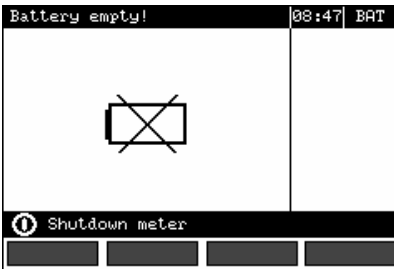

Battery fully discharged,
Measurements cannot proceed.

Note:

- The displayed **BAT** symbol means insufficient power supply voltage and the batteries need to be recharged.
- Measurements performed with an insufficient meter power supply voltage are affected by additional errors which are impossible to ascertain by the user. They cannot be relied upon for correct measurements of the tested earth ground system.

6.2 Replacement of batteries

The MRU-200-GPS meter is equipped with a package of NiMH batteries and a charger. The batteries insert into the battery compartment. The charger is built in to the meter, and must be used only to charge the original batteries. The charger is powered from an external power supply, or a car lighter socket adapter (supplied as a standard accessory).

WARNING:

Remove the test leads during replacement of the batteries as there is a risk of electric shock.

To replace the batteries:

- Remove all the test leads from the meter sockets and turn the meter off.
- Remove the four screws of the battery compartment (in the lower part of the casing),
- Remove the compartment
- Insert the new compartment in the meter
- Replace the four screws of the battery compartment.

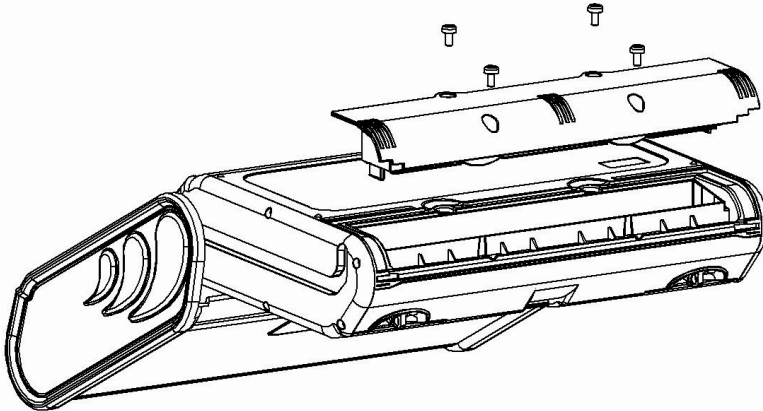

NOTE!

Do not use the meter when the battery compartment is removed or open or power it from other sources than those mentioned in the present manual.

6.3 Fuse replacement

Remove the battery compartment to get access to two replaceable fuses:

- FST 250Vac 1A, 5x20mm and
- 2A 250Vac, time-delay fuse, 5x20mm.

If the instrument or battery charger does not work, before sending it for servicing check the fuses. If they are open-circuit, replace them with identical ones. The fuses are placed in holders, near the center of the cavity. To remove the fuses use a narrow tool (e.g. a screwdriver).

6.4 Charging of batteries

Charging begins as soon as the power supply is connected to the meter, whether the meter is on or off. During charging the screen shows the battery symbol. The batteries are quick-charged; the charge time to full charge is approximately four hours. Full charge is indicated by: **Charging concluded**. To turn the device off remove the power supply plug of the power adapter.

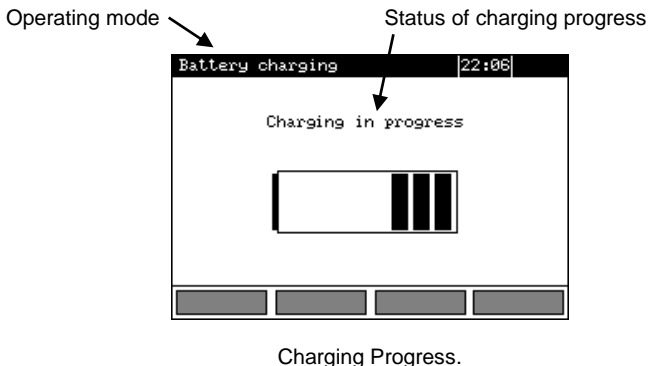

Note:

- As a result of mains-borne interference it is possible that the charging of batteries will finish prematurely. In this case, remove the power adapter plug briefly, replace the adapter plug and re-charge.

Additional information displayed by the meter

Message	Cause	Proceeding
Battery connection error!	Excessive voltage at the battery package during charging.	Check the contacts of the battery package. Should the problem persist, replace the package.
No battery!	No communication with the battery controller or battery compartment, or batteries are missing.	Check the contacts of the battery package. Should the problem persist, replace the battery.
Battery temperature too low!	The ambient temperature is lower than 10°C	It is not possible to charge the batteries at low temperatures. Place the meter in a warmer place and re-charge. The message may be displayed in the case of deep discharge of the batteries. Try turning the charger off then on repeatedly.
Precharge error	A damaged or deeply discharged battery package	The message is displayed briefly, then the precharge process begins again. If after several attempts: Battery temperature too high! is displayed, replace the battery package.

6.5 Discharging of batteries

To guarantee proper functioning of the batteries and charge-level indications, and prolong battery life, it is recommended to periodically discharge them completely and then re-charge them. To first discharge the batteries:

1

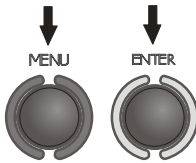

Press **MENU** and highlight **Meter settings**. Press **ENTER**.



2

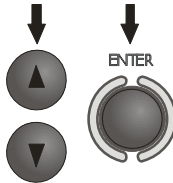

Use buttons ▲ and ▼ to select **Battery discharge** and press **ENTER**.

View the displayed text and accept.

Discharging may last up to 10 hours depending on the level of the charge of the batteries. While discharging the meter displays: **Discharge in progress**.

6.6 General principles regarding using Ni-MH batteries

- If the meter is not used for prolonged periods, it is recommended to remove the batteries and store them separately.
- Store the batteries in a dry, cool, and well-ventilated place and protect them from direct sunlight. The temperature of the storage environment should not exceed 30°C / 86°F. If batteries are stored for a long time at high temperature, their lifetime will be shorter.
- Ni-MH batteries can tolerate 500-1000 charging cycles. The batteries reach their maximum capacity after being formatted (2-3 charge and discharge cycles). The most important factor affecting lifetime of a battery is the depth of discharge. The deeper the discharge, the shorter the lifetime.
- The memory effect for Ni-MH batteries is small. They may be charged at any point with no serious consequences. However, it is recommended to discharge them completely periodically.
- During storage, Ni-MH batteries discharge at a rate of approximately 30% per month. High temperatures accelerates discharge. To prevent excessive discharge, after which it will be necessary to format them, it is recommended to re-charge the batteries periodically, even if meter is not in use.
- Modern fast chargers detect both too low and too high a temperature of batteries and react to the situation appropriately. Too low a temperature prevents charging, and could damage the battery irreparably. An increase of the temperature of the battery will stop the charging. Charging at a high temperature of the environment, in turn, causes an accelerated increase of the temperature of the battery. It will be not charged to its full capacity, and battery lifetime will be reduced.
- Quick charging charges batteries to approximately 80% of their capacity. The full use of the battery capacity may be obtained if charging is continued: the charger will charge with a low current and after a couple of hours the batteries are charged to their full capacity.
- Do not charge or use batteries in extreme temperatures. Extreme temperatures reduce the lifetime of batteries. Avoid placing devices powered from batteries in very hot or very cold environments. Observe the nominal working temperature: -10 to 50 °C / 14 to 122 °F.

7 Cleaning and maintenance

NOTE!
Use only the maintenance methods specified in this manual.

The case of the meter may be cleaned with a soft, damp cloth using all-purpose detergents. Do not use any solvents or cleaning agents which might scratch the casing (powders, pastes, etc.).

Clean the probes with water and dry them. Before probes are stored for a prolonged periods grease them with any machine lubricant.

The reels and test leads should be cleaned with water and detergents, and dried.

The electronic system of the meter does not require maintenance.

8 Storage

Observe the following recommendations when storing the meter:

- Disconnect all test leads from the meter.
- Clean the meter and all its accessories thoroughly.
- Wind the long test leads onto the reels.
- Remove the batteries if the meter is stored for long periods.
- To prevent total discharge of the batteries in prolonged periods of storage, re-charge them periodically,

9 Dismantling and disposal

Disused, and scrap electric and electronic equipment should be separated and not be placed with general waste of other types.

Disused, and scrap electric electronic equipment should be sent to a waste collection point in accordance with local regulations for the disposal of waste electric and electronic equipment, spent batteries, and associated packaging.

Before the equipment is sent to a collection point, do not open or dismantle the equipment.

10 Technical data

- The specified accuracy applies to meter terminals.
- The abbreviation „m.v.“ in the basic uncertainty definition means the measured value.

10.1 Basic data

Interference voltage measurement $99 U_N$ (RMS)

Range	Resolution	Basic uncertainty
0 to 100V	1V	$\pm(2\% \text{ m.v.} + 3 \text{ digits})$

- measurement for f_N 15 to 450 Hz
- frequency of measurements – minimum two measurements/s

Interference frequency measurement f_n

Range	Resolution	Basic uncertainty
15 to 450Hz	1Hz	$\pm(1\% \text{ m.v.} + 2 \text{ digits})$

- measurement for interference voltage $>1\text{V}$ (for interference voltage $<1\text{V}$ the following is displayed: $f=---$)

Measurement of connection and equipotential bonding resistance (two-cable method)

The measurement method: technical, in accordance with IEC 61557-5

Range of measurement in accordance with IEC 61557-4: $0,045\Omega \dots 19,99\text{k}\Omega$

Range	Resolution	Basic uncertainty
0.000 to $3,999\Omega$ *	0.001Ω	$\pm(2\% \text{ m.v.} + 4 \text{ digits})$
4.00 to $39,99\Omega$	0.01Ω	$\pm(2\% \text{ m.v.} + 2 \text{ digits})$
40 to $399,9\Omega$	0.1Ω	
400 to 3999Ω	1Ω	
4,000 to $19,99\text{k}\Omega$	$0.01\text{k}\Omega$	$\pm(5\% \text{ m.v.} + 2 \text{ digits})$

* In 0.000 to 0.045Ω range uncertainty is unspecified.

Measurement of earth resistance (3, 4-cable method)

The measurement method: technical, in accordance with IEC 61557-5

Range of measurement in accordance with IEC 61557-5: 0.100Ω to $19.99\text{k}\Omega$

Range	Resolution	Basic uncertainty
0.000 to $3,999\Omega$ *	0.001Ω	$\pm(2\% \text{ m.v.} + 4 \text{ digits})$
4.00 to $39,99\Omega$	0.01Ω	$\pm(2\% \text{ m.v.} + 2 \text{ digits})$
40.0 to $399,9\Omega$	0.1Ω	
400 to 3999Ω	1Ω	
4.00 to $19.99\text{k}\Omega$	$0.01\text{k}\Omega$	$\pm(5\% \text{ m.v.} + 2 \text{ digits})$

* For 3-cable method in 0.000 to 0.045Ω range uncertainty is unspecified.

Measurement of the auxiliary electrode resistance

Range	Resolution	Basic uncertainty
0 to 999Ω	1Ω	$\pm(5\% (R_E+R_H+R_S) + 8 \text{ digits})$
1.00 to $9.99\text{k}\Omega$	$0.01\text{k}\Omega$	
10.0 to $19.9\text{k}\Omega$	$0.1\text{k}\Omega$	

Measurement of multiple earth resistance with clamp (three-cable with clamp)

Range of measurement in accordance with IEC 61557-5: 0.120Ω to 1999Ω

Range	Resolution	Basic uncertainty
0.000 to 3.999Ω *	0.001Ω	±(8% m.v. + 4 digits)
4,00 to 39.99Ω	0.01Ω	±(8% m.v. + 3 digits)
40.0 to 399.9Ω	0.1Ω	
400 to 1,999Ω	1Ω	

* In 0.000 to 0.045Ω range uncertainty is unspecified.

Measurement of multiple earth resistance with double clamp

Range	Resolution	Basic uncertainty
0.00 to 19.99Ω	0.01Ω	±(10% m.v. + 3 digits)
20.0 to 149.9Ω	0.1Ω	±(20% m.v. + 3 digits)

Ground resistivity measurements

The measurement method: Wenner's, $\rho = 2\pi LR_E$

Range	Resolution	Basic uncertainty
0.0 to 199.9Ωm	0.1Ωm	Depends on the basic uncertainty of the R_E 4P measurement but not less than ±1 digit.
200 to 1,999Ωm	1Ωm	
2.00 to 19.99kΩm	0.01kΩm	
20.0 to 99.9kΩm	0.1kΩm	
100 to 999kΩm	1kΩm	

- distance between measurement probes (L): 1 to 50m / 164 ft.

Measurement of leakage damage current (rms)

Range	Resolution	Basic uncertainty
0,1..99,9mA ¹	0,1mA	±(8% m.v. + 5 digits)
100..999mA ¹	1mA	±(8% m.v. + 3 digits)
1,00..4,99A ^{1,2,3,4}	0,01A	±(5% m.v. + 5 digits) ^{1,3,4} unspecified ² unspecified for 0..2 A ³ unspecified for 0..1 A ⁴
5,00..9,99A ^{1,2,3,4}	0,01A	±(5% m.v. + 5 digits)
10,0..99,9A ^{1,2,3,4}	0,1A	
100 ... 300A ^{1,2,3,4}	1A	

¹ – current clamp (diameter 52mm / 2.2ins) – C-3

² – flexible Rogowski probe – F-1

³ – flexible Rogowski probe – FS-2

⁴ – flexible Rogowski probe – FSX-3

- frequency range: 45 to 400Hz

Earth resistance measurement by means of the impulse method

Range	Resolution	Basic uncertainty
0.0 to 99.9Ω	0.1Ω	±(2.5% m.v. + 3 cyfry)
100 to 199Ω	1Ω	

- impulse shape: 4/10μs or 10/350μs
- impulse measurement current: approximately 1A
- impulse peak voltage: approximately 1500V

Other technical data

- a) Insulation double-insulated, in accordance with EN 61010-1 and IEC 61557
- b) Measurement category CAT IV 300V (< 2000m above sea level), IV 255V (< 3000m above sea level) EN 61010-1 compliant
- c) Protection grade of case in accordance with EN 60529 IP54
- d) Maximum interference voltage AC + DC at which a measurement may be performed 24 V
- e) Maximum measured interference voltage 100 V
- f) Maximum interference current at which measurement of the earth ground resistance by the clamp method is performed 3 Arms
- g) Frequency of the measurement current 125Hz for the 16 2/3Hz, 50Hz, 400Hz, and 150Hz for the 60Hz mains
- h) Measurement voltage and current for 2P V<24 Vrms, I≥200 mA for R≤60 Ω
- i) Measurement voltage for 3P, 4P 25 or 50 V
- j) Measurement current (short-circuit current) for 3P, 4P >200 mA
- k) Maximum resistance of measurement electrodes 20 kΩ
- l) Insufficient clamp current level ≤0,5 mA
- m) Power supply of the meter battery package type SONEl NiMH 4,8V 4,2 Ah
- n) AC adapter battery charger 100 V to 240 V, 50 H / 60 Hz
- o) Number of measurements for R 2P >1500 (1Ω, 2 measurement/minute)
- p) Number of measurements for R_E > 1200 (R_E=10Ω, R_H=R_S=100Ω, 2 measurement/minute)
- q) Duration of a resistance measurement by means of the two-pole method <6 s
- r) Duration of a resistance and resistivity measurement by means of other methods <8 s
- s) Position Accuracy (in good weather conditions and visibility of satellites) 3m / 10ft. (50%CEP)
- t) Dimensions 288 x 223 x 75 mm / 11.3 x 8.8 x 3 ins.
- u) Weight with battery 2 kg / 4.4 lbs
- v) Operating temperature -10 to +50 °C / +14 to +122 °F
- w) Temperature range for battery charging +10 °C to +40 °C / +50 °F to +104 °F
- x) Temperature range battery charging unavailable < +5 °C / °+41F and > +50 °C / > +122 °F
- y) Reference temperature 23 ±2 °C / 73 ±4 °F
- z) Storage temperature -20 to +70 °C / -4 to +158 °F
- aa) Relative humidity 20 to 90%
- bb) Relative humidity nominal 40 to 60%
- cc) Quality standard ISO 9001
- dd) EMC meets following standards EN 61326-1:2006 and EN 61326-2-2:2006

10.2 Additional data

Data regarding additional uncertainties are useful mainly in the case the meter is used under non-standard conditions as well as for measurement laboratories for the purpose of calibration.

10.2.1 Influence of the serial interference voltage U_Z upon earth resistance measurements for functions 3P, 4P, 3P + clamp

R	Additional uncertainty [Ω]
0.000 to 3.999 Ω	$\pm (25 \cdot 10^{-4} \cdot R_E + 2 \cdot 10^{-4} \cdot \frac{V_z}{R_E}) \cdot V_z$
>3.999 Ω	$\pm (5 \cdot 10^{-4} \cdot R_E + 2 \cdot 10^{-2}) \cdot V_z$

10.2.2 Influence of the serial interference voltage V_Z upon earth resistance measurements for function p

$$\Delta_{\text{add}} [\Omega] = \pm 2,5 \cdot (10^{-3} \cdot R_E + 10^{-6} \cdot R_H \cdot V_Z) \cdot V_Z,$$

$$\text{where } R_E = \frac{\rho}{2 \cdot \pi \cdot L}$$

10.2.3 Influence of the auxiliary electrodes upon earth resistance measurements for function 3P, 4P, 3P + clamp

R_E	R_H, R_S	Additional uncertainty [%]
0.000 to 3,999 Ω	$R_H \leq 500\Omega$ and $R_S \leq 500\Omega$	within the range of the basic uncertainty
	$R_H > 500\Omega$ or $R_S > 500\Omega$ or R_H and $R_S > 500\Omega$	$\pm (\frac{R_S}{R_S + 10^6} \cdot 200 + \frac{R_H^2}{R_E \cdot R_H + 200} \cdot 5 \cdot 10^{-3} + (1 + \frac{1}{R_E}) \cdot R_H \cdot 4 \cdot 10^{-4})$
>3,999 Ω	$R_H \leq 1\text{k}\Omega$ and $R_S \leq 1\text{k}\Omega$	within the range of the basic uncertainty
	$R_H > 1\text{k}\Omega$ or $R_S > 1\text{k}\Omega$ or R_H and $R_S > 1\text{k}\Omega$	$\pm (\frac{R_S}{R_S + 10^6} \cdot 200 + \frac{R_H^2}{R_E \cdot R_H + 200} \cdot 5 \cdot 10^{-3} + R_H \cdot 4 \cdot 10^{-4})$

$R_E[\Omega]$, $R_S[\Omega]$ and $R_H[\Omega]$ are values which are displayed by the device.

For measurements with the use of ERP-1

R_E	R_H, R_S	Additional uncertainty for $V = 25 \text{ V}$ [%]
0.000 Ω to 3,999 Ω	$R_H \leq 500 \Omega$ and $R_S \leq 500 \Omega$	within the range of the basic uncertainty
	$R_H > 500 \Omega$ or $R_S > 500 \Omega$ or R_H and $R_S > 500 \Omega$	$\pm (\frac{R_S}{R_S + 10^6} \cdot 200 + \frac{R_H^2}{R_E \cdot R_H + 200} \cdot 5 \cdot 10^{-3} + (1 + \frac{1}{R_E}) \cdot R_H \cdot 4 \cdot 10^{-4})$
>3,999 Ω	$R_H \leq 1 \text{ k}\Omega$; $R_S \leq 1 \text{ k}\Omega$	within the range of the basic uncertainty
	$R_H > 1 \text{ k}\Omega$ or $R_S > 1 \text{ k}\Omega$ or R_H and $R_S > 1 \text{ k}\Omega$	$\pm (\frac{R_S}{R_S + 10^6} \cdot 200 + \frac{R_H^2}{R_E \cdot R_H + 200} \cdot 5 \cdot 10^{-3} + R_H \cdot 20 \cdot 10^{-4})$

R_E	R_H, R_S	Additional uncertainty for $V = 50 \text{ V}$ [%]
0,000 Ω to 3,999 Ω	$R_H \leq 500 \text{ } \Omega$ and $R_S \leq 500 \text{ } \Omega$	within the range of the basic uncertainty
	$R_H > 500 \text{ } \Omega$ or $R_S > 500 \text{ } \Omega$ or R_H and $R_S > 500 \text{ } \Omega$	$\pm \left(\frac{R_S}{R_S + 10^6} \cdot 200 + \frac{R_H^2}{R_E \cdot R_H + 200} \cdot 5 \cdot 10^{-3} + \left(1 + \frac{1}{R_E}\right) \cdot R_H \cdot 4 \cdot 10^{-4} \right)$
>3,999 Ω	$R_H \leq 1 \text{ k}\Omega$ i $R_S \leq 1 \text{ k}\Omega$	within the range of the basic uncertainty
	$R_H > 1 \text{ k}\Omega$ or $R_S > 1 \text{ k}\Omega$ or R_H and $R_S > 1 \text{ k}\Omega$	$\pm \left(\frac{R_S}{R_S + 10^6} \cdot 200 + \frac{R_H^2}{R_E \cdot R_H + 200} \cdot 5 \cdot 10^{-3} + R_H \cdot 15 \cdot 10^{-4} \right)$

$R_E[\Omega]$, $R_S[\Omega]$ and $R_H[\Omega]$ are values which are displayed by the device.

10.2.4 Influence of the auxiliary electrodes upon earth resistance measurements for function p

Additional uncertainty [%]
$\pm \left(\frac{R_H \cdot (R_S + 30000\Omega)}{R_E} \cdot 3,2 \cdot 10^{-7} + 4 \cdot 10^{-4} \cdot \sqrt{R_H^2 + R_S^2} \right)$

$R_E[\Omega]$, $R_S[\Omega]$ and $R_H[\Omega]$ are values which are displayed by the device.

10.2.5 Influence of the auxiliary electrodes upon earth resistance measurements by means of the percussive method

R_H	Z_E	Uncertainty [%]
$R_H \leq 150\Omega$	0,0...199 Ω	within the range of the basic uncertainty
$R_H > 150\Omega$	0,0...4,9 Ω	$\pm \left(\frac{R_H - 100}{Z_E} \cdot 4 \cdot 10^{-2} \right)$
	5,0...199 Ω	$\pm ((R_H - 100) \cdot 7 \cdot 10^{-3})$

$Z_E[\Omega]$ and $R_H[\Omega]$ are values which are displayed by the device.

10.2.6 Influence of the interference current I_z upon the result of the earth resistance measurement 3P+clamp

The MRU-200 meter may perform a measurement, if the value of the interference current does not exceed 3A rms and the frequency complies with the value set in the MENU.

R_E	V_{wy}	Uncertainty [Ω]
$\leq 50\Omega$	25V	$\pm (5 \cdot 10^{-3} \cdot R_E \cdot I_{zakl}^2)$
	50V	$\pm (2,5 \cdot 10^{-3} \cdot R_E \cdot I_{zakl}^2)$
$> 50\Omega$	25V	$\pm (70 \cdot 10^{-6} \cdot R_E^2 \cdot I_{zakl}^2)$
	50V	$\pm (50 \cdot 10^{-6} \cdot R_E^2 \cdot I_{zakl}^2)$

If the interference current exceeds 3A the measurement is cancelled.

10.2.7 Influence of interference current upon the result of the earth resistance measurement using double clamps

The MRU-200 meter may perform a measurement if the value of the interference current does not exceed 3A rms and the frequency complies with the value set in the MENU.

R_E	Uncertainty [Ω]
0.00 to 4.99 Ω	within the range of the basic uncertainty
5.00 to 19.9 Ω	$\pm (5 \cdot 10^{-3} \cdot R_E^2 \cdot I_{zakl}^3)$
20.0 to 149.9 Ω	$\pm (6 \cdot 10^{-2} \cdot R_E^2 \cdot I_{zakl}^3)$

If the interference current exceeds 3A the possibility of measurement is blocked.

10.2.8 Influence of the relation of the resistance measured with clamp for the multiple earthing branch to the resultant resistance (3P + clamp)

R_C	Uncertainty [Ω]
$\leq 99.9\Omega$	$\pm (3 \cdot 10^{-3} \cdot \frac{R_C}{R_w^2})$
$> 99.9\Omega$	$\pm (6 \cdot 10^{-2} \cdot \frac{R_C}{R_w^2})$

$R_C[\Omega]$ is the value of the resistance measured with clamps for the branch displayed by the device, and $R_w[\Omega]$ is the value of the resultant multiple earth resistance.

10.2.9 Additional uncertainties in accordance with IEC 61557-4 (2P)

Influencing factor	Symbol	Additional uncertainty	
Location	E_1	0%	
Power supply voltage	E_2	0% (bAt not displayed)	
Temperature	E_3	$R \leq 3.999\Omega$	$\pm 0.3 \text{ digits}/^\circ\text{C}$
		$R > 3.999\Omega$ and $< 1\text{k}\Omega$	$\pm 0.2 \text{ digits}/^\circ\text{C}$
		$R \geq 1\text{k}\Omega$	$\pm 0.07\% / ^\circ\text{C}$ $\pm 0.2 \text{ digits}/^\circ\text{C}$

10.2.10 Additional uncertainties in accordance with IEC 61557-5 (3P, 4P, 3P + clamp)

Influencing factor	Symbol	Additional uncertainty	
Location	E_1	0%	
Power supply voltage	E_2	0% (bAt not displayed)	
Temperature	E_3	$R \leq 3.999 \Omega$	$\pm 0.3 \text{ digits}/^\circ\text{C}$
		$R > 3.999\Omega$ and $< 1\text{k}\Omega$	$\pm 0.2 \text{ digits}/^\circ\text{C}$
		$R \geq 1\text{k}\Omega$	$\pm 0.07\% / ^\circ\text{C}$ $\pm 0.2 \text{ digits}/^\circ\text{C}$
Serial interference voltage	E_4	In accordance with formula In 10.2.1 ($V_2=3\text{V } 50/60/400/16 \text{ 2/3Hz}$)	
Resistance of electrodes and auxiliary earth electrodes	E_5	In accordance with the formula in 10.2.3	

11 Accessories

11.1 Basic accessories

- 30 cm / 1 ft probes (4 pieces) – **WASONG30**
- 2.2 m / 7.2 ft. black test lead with banana plugs at one end, with a test prod – **WAPR2X2BLBB**
- 25 m / 82 ft. blue (**WAPRZ025BUBBSZ**) and red (**WAPRZ025REBBSZ**) test leads (2 pieces) with banana plugs at both ends, on reels for distance measurements of extensive earthing systems
- 1.2 m / 3.9 ft. red test lead – **WAPRZ1X2REBB**
- 50 m, 164 ft. yellow shielded test lead wound upon a reel with banana plugs at both ends – **WAPRZ050YEBBSZE**,
- Black crocodile clip – **WAKROBL20K01**
- Red crocodile clip – **WAKRORE20K02**
- Vice – **WAZACIMA1**
- Rechargeable batteries – **WAAKU07**
- Meter protective cover – **WAFUTL2**
- Neck strap, two pieces (short and long) – **WAPOZSZEKPL**
- USB cable – **WAPRZUSB**
- Adapter to charge the battery from a 12V vehicle lighter socket – **WAPRZLAD12SAM**
- Charger / AC adapter (for different countries) – **WAZASZ7**
- Operating manual

11.2 Additional accessories

Additional accessories are available from Sonel and authorized distributors:

WASONG80



- *80cm measurement probe to be driven into the ground*

WACEGC3OKR



- *Reception clamp C-3*

WACEGN1BB



- *Transmission clamp N-1*

WACEGF1OKR



- *Flexible clamp F-1*

WACEGFS2OKR



- *Flexible clamp FS-2*

WAFUTL3



- *80cm probe protective cover*

WAPOJ1



- *Batteries compartment*

WACEGFSX3OKR



- *Flexible clamp FSX-3*

WAWALXL3



- *Case XL3 for the meter and accessories*

LSWGBMRU200

- *Certificate of calibration*

12 Positions of the meter's cover

The movable cover enables using the meter in various positions.

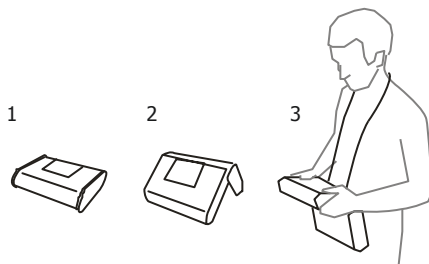

1 – Cover as the bottom of the meter

2 – Cover used as a support

3 – Cover in the position that enables the meter to be suspended by the neck straps

13 Manufacturer

The manufacturer of the device, which also provides guarantee and post-guarantee service is the following company:

SONEL TEST & MEASUREMENT, Inc.

Santa Clara, Ca 95054

Tel: 408 74 988 1346

Fax: 408 988 4869

E-mail: testsupport@soneltest.com

Web page: www.soneltest.com

SONEL S.A.

ul. Wokulskiego 11

58-100 Świdnica

Poland

Tel: +48 74 858 38 60

Fax: +48 74 858 38 09

E-mail: export@sonel.pl

Web page: www.sonel.pl

Attention:

Service repairs must performed only by an authorized Sonel service center.



SONEL Test & Measurement, Inc.

Santa Clara, Ca 95054 USA

tel. +1 (408) 898 2215

fax +1 (408) 988 4869

E-mail: testsupport@soneltest.com

Web: www.soneltest.com

SONEL S. A.

58-100 Świdnica

Poland

tel. +48 74 858 38 60

fax +48 74 858 38 09

E-mail: export@sonel.pl

Web page: www.sonel.pl